

Emux



www.metrodata.co.uk

**Metrodata Emux
E1 Service Delivery Multiplexer
Installation Guide**

Metrodata Ltd
Fortune House
Crabtree Office Village
Eversley Way
Egham
Surrey TW20 8RY
United Kingdom

tel: +44 (0) 1784 744700
fax: +44 (0) 1784 744730
email: sales@metrodata.co.uk
website: www.metrodata.co.uk/support

Part No: 76-02-075B

CONTENTS

1	INTRODUCTION	1
1.1	About the Emux	1
1.2	Emux applications	2
1.3	Safety	2
1.4	Electromagnetic Compatibility	2
1.5	EN55022 Declaration	3
1.6	FCC Declaration	3
1.7	WEEE Directive	3
1.8	RoHS Compliance	3
2	INTRODUCING THE EMUX	4
2.1	Front & rear panels	4
2.1.1	Front panel LEDs	4
2.2	Power Supply	4
2.3	Alarm Extension Relay	5
2.4	Terminal port	6
2.5	Uplink ports	6
2.6	Balanced RJ45 E1 Port Layout	7
3	INSTALLATION & SET-UP	8
3.1	Power-Up Sequence	8
3.2	Main Set-up Menu	9
3.3	Connecting terminals to the Emux (V.24 set-up menu)	9
3.3.1	TTY terminal	9
3.3.2	VT100/VT220 and ANSI terminals	10
3.3.3	Default settings	11
3.4	Unit Set-up Checklist	12
3.4.1	Navigating the User Interface	13
3.5	Global status	13
3.6	Alarm extension	14
3.7	Dataport set-up	14
3.8	System Menu	15
3.8.1	Setting the time & date	15
3.8.2	Setting the node name	16
3.8.3	Setting the password	16
3.8.4	Welcome Screen	17
3.8.5	Software version	17
3.8.6	Output config	17
3.8.7	Input config	18
3.8.8	Warm start	18
3.8.9	Cold start (Caution!)	18
3.8.10	Event Logs	19
3.9	Performance data	20
3.10	Management menu	20
3.10.1	Setting the Unit IP address	21
3.10.2	Setting a default route	22

3.11	Management	23
3.11.1	Management menu	23
3.11.2	Telnet Option	24
3.11.3	TFTP	25
3.11.4	Ping	25
3.11.5	SNMP configuration	26
3.11.6	Read/Write/Trap communities	26
3.11.7	Managers	26
3.11.8	Contact person	27
3.11.9	Location	27
3.11.10	Statistics (Stats)	27
3.12	Trap alarms	28
4	DATA PORT CONFIGURATION	29
4.1	Uplink port configuration	29
4.1.1	Module type	29
4.1.2	SFP1, SFP2 type	30
4.1.3	Active SFP select	30
4.1.4	Restore Primary (SFP1)	30
4.1.5	SFP1, SFP2 status	30
4.1.6	Switchover time-out	30
4.1.7	Scrambler mode	31
4.1.8	Tx clock source	31
4.1.9	Uplink BERT	31
4.2	E1 port configuration	32
4.2.1	State	33
4.2.2	Long haul/Short haul	33
4.2.3	E1 BERT	33
5	SNMP MANAGEMENT	34
5.1	MIB-2, sysObjectID	34
5.2	Traps	34
5.2.1	Trap Enterprise Field	34
5.2.2	Trap Interface Field	35
5.2.3	Trap types	35
5.2.3.1	Generic Trap 1, Warm Start	36
5.2.3.2	Generic Trap 2, Link Down	36
5.2.3.3	Generic Trap 3, Link Up	36
5.2.3.4	Generic Trap 6, Enterprise Specific Trap	37
6	FAULT FINDING	38
6.1	Top level alarm summary	38
6.2	Global status overview	38
6.3	Loopbacks	39
6.4	BERT testing	40
6.4.1	E1 BERT	41
6.4.2	Uplink BERT	41
6.4.3	Start/Stop test, E1 or Uplink	41

7	PERFORMANCE	43
7.1	Performance data	43
7.2	Errors and Alarms	43
7.2.1	Uplink port alarms & errors	44
7.2.2	E1 port alarms & errors	44
7.3	Performance menu	47
7.3.1	Interface	47
7.3.2	Display mode	47
7.3.3	Summary style	47
7.3.4	Physical layer stats	48
7.3.5	Error type	48
7.4	Physical layer stats – Reports	48
7.4.1	Full Report	48
7.4.2	Rolling report	49
7.5	Physical layer stats - Summaries	50
7.5.1	Screen presentation	50
7.5.2	Presentation display modes	50
7.5.3	Summary style	51
7.5.4	Summary display - COUNTS style	51
7.5.5	Summary display - G.821 style	52
7.5.6	Summary display - Percent G.821 style	53

Metrodata Ltd

No part of this publication may be reproduced, transmitted, transcribed, stored in a retrieval system, or translated into any language or computer language, in any form or by any means, electronic, mechanical, magnetic, optical, chemical, manual or otherwise, without the prior written permission of

Metrodata Ltd,
Fortune House,
Crabtree Office Village,
Eversley Way,
Egham, Surrey, TW20 8RY,
United Kingdom.

Tel: +44 (0) 1784 744700

Fax: +44 (0) 1784 744730

e-mail: sales@metrodata.co.uk

www: <http://www.metrodata.co.uk>

ftp: <ftp://ftp.metrodata.co.uk>

Disclaimer

Metrodata Ltd makes no representations or warranties with respect to the contents hereof and specifically disclaims any implied warranties or merchantability or fitness for any particular purpose. Further, Metrodata Ltd reserves the right to revise this publication and to make changes from time to time in the content hereof without obligation of Metrodata Ltd to notify any person of such revision or changes.

Trademarks

The Trademarks of other Corporations which may be used in this manual are hereby acknowledged.

Copyright © 2010 by Metrodata Ltd
All Rights Reserved

1 INTRODUCTION

1.1 About the Emux

The Metrodata Emux family of products provides transport of multiple E1 circuits over a dual resilient fibre interface.

Different Emux models provide a range of price/performance to suit specific customer applications, as shown below:

Emux-4 4 Port E1 with Dual fibre Interface

Emux-8 8 Port E1 with Dual fibre Interface

Emux-16 16 Port E1 with Dual fibre Interface

The fibre interfaces are offered using SFP modules and support many different options, as shown below:

OC-3 1310 MM SR-1 (2km)

OC-3 1310 SM IR-1 (15 km)

OC-3 1310 SM LR-1 (40 km)

OC-3 1550 SM LR-2 (80 km)

The dual diverse fibres provide resilience, since a fault on one fibre will force the Emux to switch automatically to the alternate fibre link, thus minimising the service outage. Port switch over is completed within 50mS of a fault being detected. A configured time-out is used to prevent port flapping between fibre ports.

The E1 ports are presented on RJ-45 connectors and offer an NT configuration for direct connection to TE equipment such as Routers or PBX's. If the Emux is connected to an E1 NT port such as a DSU/NTU, then a cross-over connection is required.

The Emux provides extensive menu-driven options to ensure inter-operability with other vendor equipment. Comprehensive alarm reporting and performance monitoring permits quick and easy diagnosis of network problems. The Emux may be managed either locally using a VT100/220 terminal, or remotely via the LAN management port using either Telnet or SNMP.

1.2 Emux applications

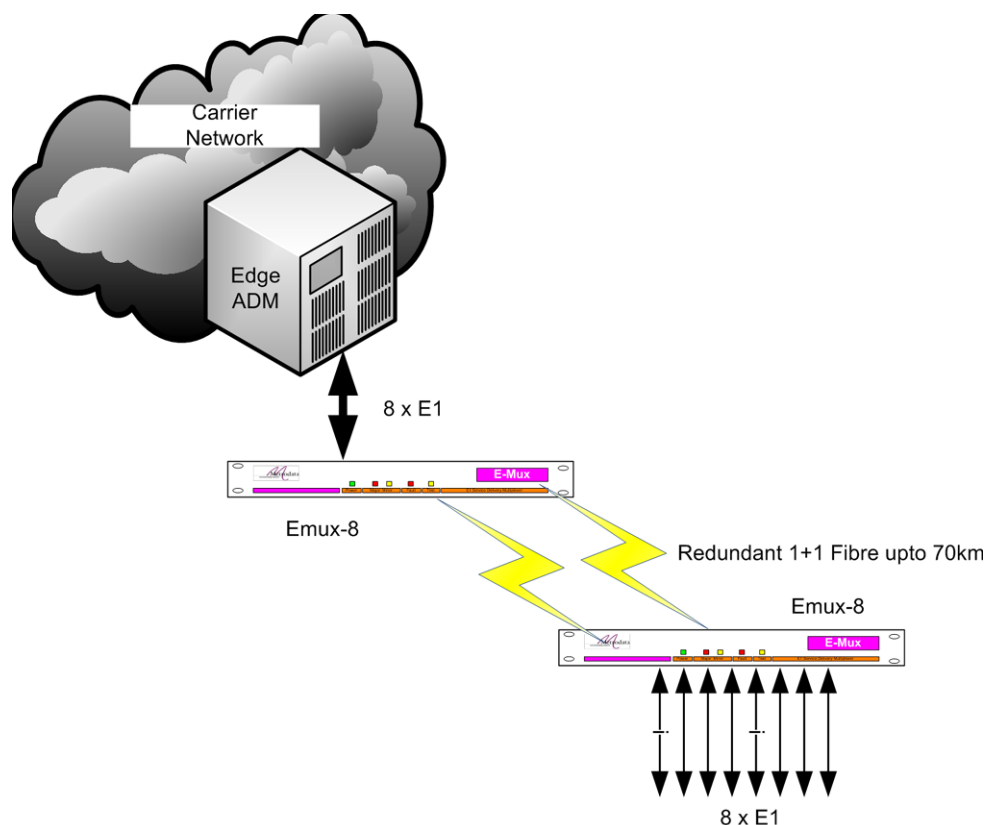

Figure 1. 1 Emux application

An Emux may be used by Network operators to fan out E1 services from their main POP sites. Using a National carrier network, the Emux is attached to the local ADM and then distributed over fibre. At the remote site, the individual E1 services may then be fanned out using an Emux.

1.3 Safety

The Emux should not be connected to cabling which would be required by BS6701 to be equipped with over-voltage protection. The following ports are designated SELV (Safety Extra Low Voltage) within the scope of EN41003:

- E1 Serial line ports
- Terminal port
- Remote Management port
- Alarm extension port

These ports should only be connected to SELV ports on other equipment in accordance with EN60950 clause 2.3.

1.4 Electromagnetic Compatibility

In order to ensure EMC compliance all signal and data cables and connectors must use a screened connector shell with a screened cable. The cable screen must be terminated to the screened connector shell and not connected to any pins of the connector. Failure to use the correct connector may compromise EMC compliance.

1.5 EN55022 Declaration

The Emux is a Class A product. In a domestic environment it may cause radio interference in which case the user may be required to take adequate measures.

1.6 FCC Declaration

This equipment has been tested and found to comply with the limits for a Class A digital device, pursuant to Part 15 of the FCC Rules. These limits are designed to provide reasonable protection against harmful interference when the equipment is operated in a commercial environment. This equipment generates, uses, and can radiate radio frequency energy and, if not installed and used in accordance with the instruction manual, may cause harmful interference to radio communications. Operation of this equipment in a residential area is likely to cause harmful interference in which case the user will be required to correct the interference at its own expense.

1.7 WEEE Directive

The Emux is covered by Directive 2002/96/EC (OJ:L37/24/2003) on waste electrical and electronic equipment (The WEEE Directive). Units must therefore not be disposed of in a standard landfill.

1.8 RoHS Compliance

The Emux is compliant with the EU RoHS directive 2002/95/EC. The RoHS directive bans the use of six hazardous materials in products placed on the market after July 1st 2006. The six banned materials are Lead, Mercury, Hexavalent Chromium, Polybrominated Biphenyls, Polybrominated Diphenyl Ethers and Cadmium.

The Emux product is manufactured using a lead-free soldering process and as such is RoHS 6/6 compliant.

2 INTRODUCING THE EMUX

2.1 Front & rear panels

All connections into and out of the Emux are made through the rear panel.

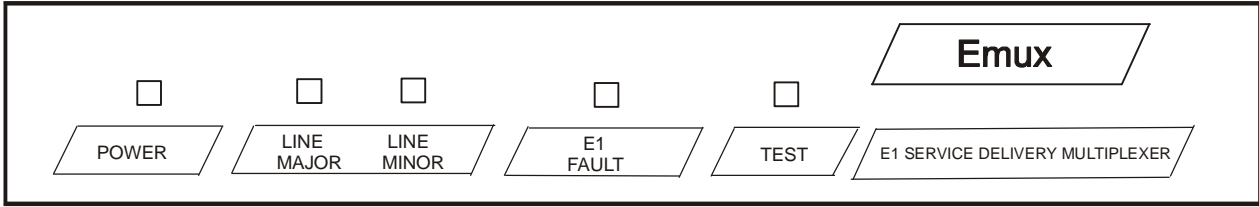

Figure 2.1 Emux front panel

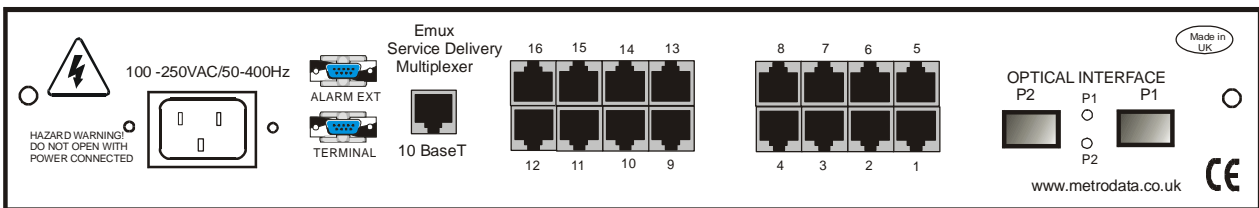

Figure 2.2 Emux rear panel

2.1.1 Front panel LEDs

LED	Colour	Meaning
Power	Green	Power is being received.
Uplink Line		
Line Major	Red	LOS, LOF, alarm is present
Line Minor	Yellow	
E1 Fault		
Fault	Red	LOS (Major) or AIS (Minor) fault on any E1 line
Test		
	Yellow	Local loop test in progress
	Unlit	No test in progress

Figure 2.3 Front panel LEDs

2.2 Power Supply

The Emux is powered by an internal mains-fed power supply. The mains input voltage is 100-250VAC, 50/400Hz with a maximum current of 120mA. The units are fitted with an internal 250mA fuse. Mains power is connected via an IEC inlet on the rear panel.

An alternative -48VDC power supply is available on all units as a custom order item. The supply definition of the DC supply is minus 36 to minus 72 VDC, 200-100 mA. DC power is supplied via a 3 pin Buccaneer socket fitted to the rear panel. A Buccaneer plug is supplied with the unit for customer's own wiring. The connections are labelled on the rear panel of the Emux as shown in the schematic below.

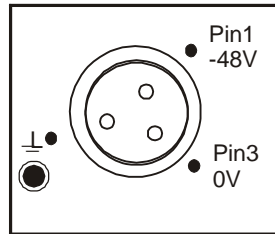

Figure 2. 4 Buccaneer DC socket

On some units, an additional Ground stud may be located on the rear panel to permit a separate Ground connection to be made.

Pin no	Connection
1	-48VDC
2	Ground
3	0VDC

Figure 2. 5 -48VDC connections

The Emux must be connected to mains safety earth for correct operation. Excessive voltages are present inside the unit. There are no user serviceable parts inside the unit, and the cover should not be removed by unqualified personnel. The unit must not be exposed to damp or condensing conditions.

The power consumption of each model in the range is shown below, together with the current consumption over the operating voltage ranges.

Product	Watts Power Consumption	Current Range mA for 100-250 VAC	Current Range mA for -40 to -72 VDC
Emux-4 Emux-8 Emux-16	15.0	150 - 60	375 - 210

Figure 2.6 Power consumption

The Emux must be connected to mains safety earth for correct operation. The BC1X00 power supply should be connected to a supply socket that is physically located close to the unit and is easily accessible.

2.3 Alarm Extension Relay

The Emux offers an Alarm relay to provide an external warning of problems which may arise. The interface is presented on an RJ45 connector, and offers both normally open and normally closed contacts. Maximum contact rating is 1.5 Amp at 125 VDC.

The normal state is the powered up, non-alarmed state such that a unit will report an alarm when it is subject to power failure. The connections are shown in the table below:

Pin	Contact
1	Normally closed
2	Normally open
3	Common
4	Not connected
5	Not connected
6	Not connected
7	Not connected
8	Not connected

Figure 2.7 Alarm extension RJ45 connections

2.4 Terminal port

The terminal port has a 9-way D-type female connector with a standard PC-type connector layout as shown below:

Pin	Signal
1	DCD
2	Receive data
3	Transmit data
4	Not connected
5	Signal ground
6	Data set ready (DSR)
7	Ready to send (RTS)
8	clear to send (CTS)
9	Not connected

Figure 2.8 Terminal port layout

The terminal port factory default configuration is shown below:

Config item	Setting
Baud rate	19200
Parity	None
Character	8 bits
Stop bits	2
Flow control	Xon/Xoff

Figure 2.9 Terminal port config

2.5 Uplink ports

See Section 4.1 for a description of the labelling and configuration of the Uplink ports

2.6 Balanced RJ45 E1 Port Layout

An Emux may be equipped with 4, 8 or 16 E1 ports with connectors on the rear panel of the unit. The layout of each of the female RJ45 E1 ports is shown below:

Pin	Signal
1	Rx tip
2	Rx ring
3	Rxshield
4	Tx tip
5	Tx ring
6	Tx shield
7	Not connected
8	Not connected

Figure 2.10 RJ45 E1 port layout

See Section 4.2 for a description of the labelling and configuration of the E1 ports.

3 INSTALLATION & SET-UP

This section describes the basic procedures needed to make a simple installation of the Emux. A terminal or PC with a terminal emulator is assumed to be connected to the Emux terminal port in order to access the menu system. Note that the setting-up of the Uplink and E1 ports is described separately in Section 4 of this manual.

3.1 Power-Up Sequence

When the Emux is powered up, it performs several system tests. After a few seconds the start-up screen is shown on the terminal. Figure 3.1 below is an example only:

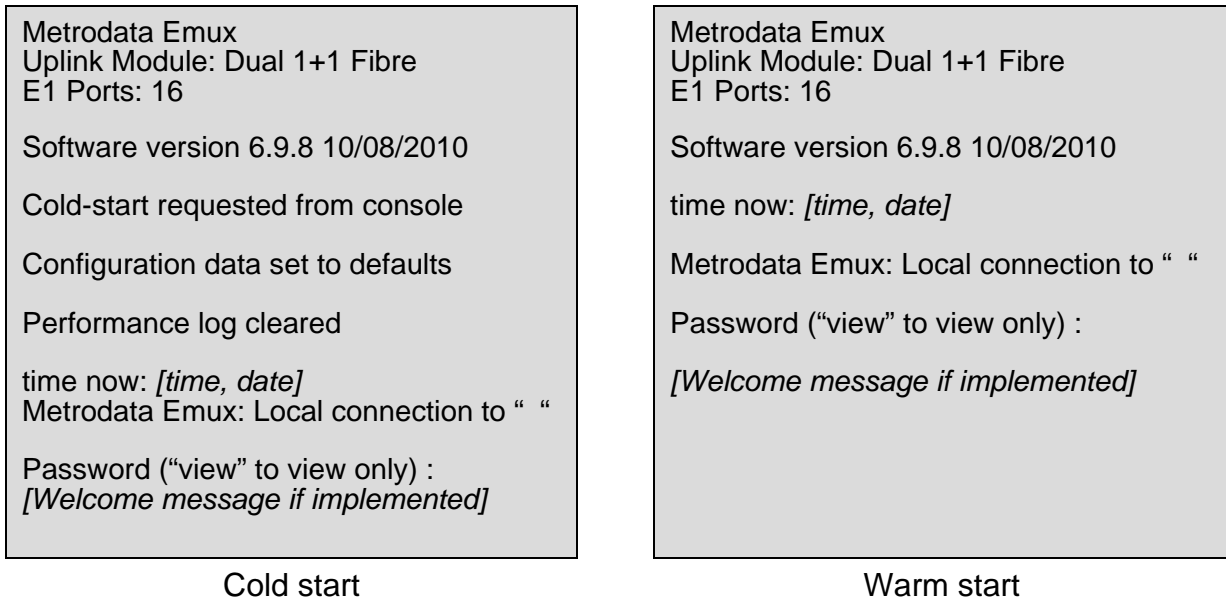

Figure 3.1 Start-up screens

In order to check or change any of the operating parameters, you will first need to gain access to the Emux’s software by logging in. Press any key, and a logon message will be displayed:

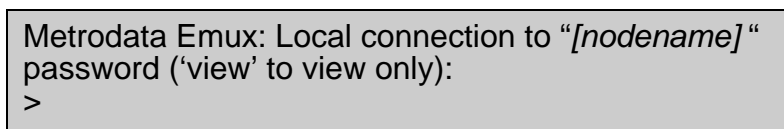

Figure 3.2 Logon screen

There are two levels of user - Observer, or Operator. If you type *VIEW* as the password, you will only be able to look at the current settings, and will not be able to change any of them. If you enter the correct operator password, you can change any parameters that are not defined as read-only.

The default operator password is the same as the model number, i.e. *emux*. When you enter the appropriate password, you will be presented with the *MAIN SET-UP* menu. All of the Emux’s operating parameters are accessed through this initial menu.

Note that the procedure for connecting a management terminal to the Emux is described first in this section, so that the Emux menus can be accessed as a first step in setting-up the Emux.

3.2 Main Set-up Menu

The first screen to be accessed is the MAIN SET-UP menu shown below

MAIN SET-UP	
Global status	<display>
alarm eXtension	<menu>
Data port set-up	<menu>
V.24 set-up	<menu>
Management	<menu>
System	<menu>
Testing	<menu>
Performance data	<menu>

Figure 3.3 Main set-up menu

3.3 Connecting terminals to the Emux (V.24 set-up menu)

The display of the menu, and the way you select menu options, will depend on which type of terminal you have connected to the unit and which version of the Emux firmware you have.

3.3.1 TTY terminal

With a TTY terminal, options are selected by pressing the first capital letter in the name. Generally, this will be the first letter, but where two menu options start with the same letter one of them will have another letter capitalised. An example of a TTY display is shown below:

MAIN SET-UP	
Global status	<display>
alarm eXtension	<menu>
Data port set-up	<menu>
V.24 set-up	<menu>
Management	<menu>
System	<menu>
Testing	<menu>
Performance data	<menu>
Select item by using first CAPITAL letter of name	
<escape> - exit menu	

Figure 3.4 TTY Main set-up menu

When you press a letter which leads to a further menu, the screen will scroll up and the new menu will be displayed.

Pressing a letter corresponding to a menu option will lead to additional prompts at the bottom of the screen:

<space>	- change value
<enter>	- save new value
<escape>	- exit without saving

Figure 3.5 Prompt screen

The current value of that option will then be shown. Each time you press the space bar, the next value will be displayed, cycling through the available values. When the required value is displayed, simply press the <enter> key to accept the value or press <escape> to cancel your choice.

3.3.2 VT100/VT220 and ANSI terminals

The displays you see on a VT100/VT220 or an ANSI terminal are very similar, and an example is shown below:

MAIN SET-UP	
Global status	<display>
alarm eXtension	<menu>
Data port set-up	<menu>
V.24 set-up	<menu>
Management	<menu>
System	<menu>
Testing	<menu>
Performance data	<menu>

HIGHLIGHTED letter - select item
<escape> - exit menu

Figure 3.6 VT/ANSI Main set-up menu

When you press a letter which leads to a further menu, the screen will be refreshed without scrolling, displaying the new menu. If you press a letter corresponding to a menu option, the value opposite that option will be highlighted. You will also see the prompts at the bottom of the screen, similar to the TTY display

:

<space>	- change value
<enter>	- save new value
<escape>	- exit without saving

Figure 3.7 Prompt screen

Pressing the space bar will cause the next available value to be displayed opposite the option. When the required value is displayed, simply press the <enter> key to accept the value or press <escape> to leave the existing value unchanged. This process with the space bar is called toggling, and is referred to later on in this manual.

3.3.3 Default settings

The terminal must be set to the Emux's default values after performing a cold start. Next, the Emux's V.24 settings can be changed using the *V.24 SET-UP* menu, which is accessed from the *MAIN SET-UP* menu. The V.24 menu leads to a *V.24 SET-UP* sub-menu

V.24 SET-UP	
Usage	Console
Console set-up	<menu>

Figure 3.8 V.24 sub-menu

The item **USAGE** can be toggled to Console or Disabled. In **DISABLED** state, the terminal set-up cannot be altered. This is a security feature for some types of application environment. When **USAGE** is set to Console, the V.24 menu can be accessed for terminal set-up. The default terminal is a Teletype (*TTY*), but the vast majority of users will employ a *VT100/220* or an *ANSI* terminal either directly or on a PC via a terminal emulator. The *TTY* output screens do not have graphic capability, and are therefore not so easy to read when setting up the system. The **CONSOLE SET-UP** menu is shown below

CONSOLE SET-UP	
Terminal type	VT100/220
via Modem	No
Baud rate	19200
Parity	None
Data bits	8
Stop bits	2
Load new config	

Figure 3.9 Console set-up menu

After a making change in the Emux's stored terminal set-up (with the terminal on default settings), select *LOAD NEW CONFIG* on the menu screen. The physical terminal must then be re-set to correspond to the new values stored in the unit.

V.24 Item	Defaults	Options
Terminal type	TTY	TTY, VT100/220, ANSI
Baud rate	9600	2400, 4800, 9600, 19200
Parity	None	Odd, Even
Data bits	8	7 or 8
Stop bits	1	1 or 2
Flow control	Xon/Xoff	

Figure 3.10V.24 Terminal set-up defaults and options

3.4 Unit Set-up Checklist

Emux units are used in pairs, one at each end of a WAN link. This section acts as a checklist for setting up each unit before establishing a valid configuration for a particular application. It assumes that you have already connected the unit as required, and logged in with the Operator password. The procedure below should be carried out on **both** units.

Step 1: Set Terminal

Set your terminal's communication parameters to the Emux's V.24 default values, then switch on power to the Emux.

Step 2: V.24 Set-Up Menu

Establish the communication parameters so that the Emux and the terminal are using the same settings. Set the terminal parameters at first to the default values, which are listed in Section 3.4

Change the Emux's *BAUD RATE*, *PARITY*, *DATA BITS* and *STOP* bits if necessary, then select *LOAD NEW CONFIG*.

If you have changed any of the default settings, you will now need to update them on the physical terminal, so that the Emux and the terminal are still on identical settings.

Step 3: Local Node - General Set-Up Menu

Check the current time and date, and change them if necessary as already described. Check the "[nodename]" of the local Emux, and change it if necessary. Check the *OPERATOR* Password, and change it if necessary.

Step 4: Configure Emux

You may now proceed to configure your Emux's for your application.

3.4.1 Navigating the User Interface

The Emux uses a simple menu-based interface. Menu items may be selected by typing the first capital letter of the option; e.g. for Global status, type <G> or <g>. Sometimes the capital letter is not the first letter of the menu option, but is contained within the label; e.g. alarm eXtension, which is selected by typing <x>.

On the right hand side of the menu display screen is a label which indicates the type of action available:

<menu> indicates that a sub-menu will be entered and displayed on the screen
 <display> indicates that an information display will be presented - usually this is status or statistics.

Additional keys may be used to navigate the menu system:

<ESC> exits the current menu, or logs out of the MAIN SET-UP menu
 <SPACE> toggles through a list of selectable options
 <ENTER> selects an item that toggling has displayed

3.5 Global status

Metrodata Emux " "					Alarms: Major	
GLOBAL STATUS					History last cleared:	
					18/10/2010 15:36:09	
Port	State	Diag	Alarms	Errors	Uplink Module: Dual 1+1 Fibre	
Uplink	Up		LOS		SFP1: OC-3 MM IR	
E1 1	Up		LOS		SFP2:Not fitted	
E1 2	Down					
E1 3	Up		LOS			
E1 4	Up		LOS			
<Escape> - exit, C - clear, other key - refresh						

Figure 3.11 Global status screen

The GLOBAL STATUS screen displays a summary of the state of the Emux unit. Only those links that are in the UP state are reported. Alarms and errors are listed to provide a snapshot of the operational state of the unit.

3.6 Alarm extension

ALARM EXTENSION	
clear A larm outputs	<display>
U plink	<menu>
E 1 port	<menu>

HIGHLIGHTED letter - select item
<escape> - exit menu

UPLINK	
0 - LOS	Major
1 - LOF	Major
3 - AIS	Minor
4 - RAI	Minor
9 - FB	Minor

E1 PORT 3	
0 - LOS	Major
3 - AIS	Minor

Figure 3.12 Alarm extension menus

The first menu item requests alarms to be cleared. The display screen lists the alarms that have been cleared by this action. Note that the number listed on the alarm screen denotes the number of the alarm, and is not a port number.

The next two items select which port type is to be examined. For the E1 ports, the user is requested to nominate the port for display:

Enter port 1 - 16
>

3.7 Dataport set-up

Please see Section 4 of this manual

3.8 System Menu

The system menu provides the basic administrative configuration items for the Emux and should be configured as the first step in the process of configuring the Emux

SYSTEM	
Time & date	<menu>
Node name	
Password	*****
“View” user.	Enabled
weLcome screen	<menu>
Software version	6.5
Output config	<display>
Input config	
Warm start	
Cold start	
Event logs	<menu>

<space>	- change value
<enter>	- save new value
<escape>	- exit without saving

Figure 3.13 System menu

3.8.1 Setting the time & date

TIME & DATE	
local Time	12.23.39>
local Date	Mon 7/9/2009
time Zone	+0
NTP server	0.0.0.0
Last sync'd	never
Sync now	

The Emux supports the use of NTP to provide an accurate real time clock function. In applications where NTP is not available, the Emux may be configured manually with current time & date settings.

According to NTP protocol, the Emux will wait for a random period of between 1 and 5 minutes before requesting an update.

if NTP is available, the following parameters need to be set:

TimeZone +/- 12	Since NTP uses GMT, time zone adjustment allows the correct time to be configured anywhere in the world.
NTP server	Enter the IP address of the network NTP server

3.8.2 Setting the node name

It is useful to enter a meaningful name for the unit. The node name is entered as a string of up to 16 alphanumeric characters. Spaces are included in the 16 character limit.

3.8.3 Setting the password

The password that permits access to the menu system can be changed via the SYSTEM menu. The default password is "emux".

To change to a more secure password, select the menu item PASSWORD. The screen will display the following message:

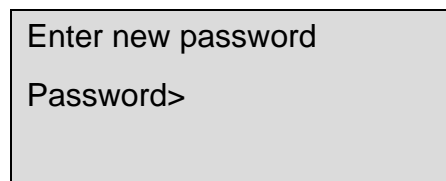

```
Enter new password
Password>
```

Figure 3.14 Password entry screen

Enter the new password using up to 16 alphanumeric characters. For security each character is shown on the screen as an asterisk (*****). Once the new password has been entered, the display changes to:

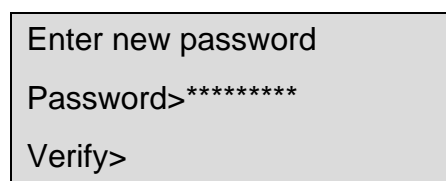

```
Enter new password
Password>*****
Verify>
```

Figure 3.15 Second password screen

Re-enter the new password. If it agrees with the first entry, the unit will require the new password for the next logon action.

3.8.4 Welcome Screen

The welcome screen option provides a tool for users to design their own welcome screens for the Emux start-up process. The welcome message is typed in line-by-line, and appears on the start-up screen below the configuration data (see Figure 3.1 at the beginning of this section).

WELCOME SCREEN	
Welcome screen	Enabled
1st line	
2nd line	
3rd line	
8th line	
Clear all text	
Display screen	<display>

WELCOME SCREEN	
Welcome screen	Disabled

Figure 3.16 Enabled & Disabled welcome screen options

3.8.5 Software version

This display item shows the version number of software installed on the Emux.

3.8.6 Output config

This item facilitates the outputting of config information to an intelligent terminal or PC connected to the Emux's terminal port and set up with a terminal emulator. When *OUTPUT CONFIG* is selected from the menu screen, the following message appears:

```

Metrodata Emux:                                     Alarms: None
Start capture then press a key
After transfer, stop capture then press another key.
# Metrodata Configuration Dump#
g.v=0
p.0.e=1
p.0.i=4
p.0.v=1
n.1.p=0.192.129.0.17.25
m.0.p=12
f.2.s=0
f.6.s=1
    
```

Figure 3.17 Metrodata Configuration dump file

3.8.7 Input config

This item facilitates uploading of config information from a stored Text file into a Emux. It also requires the use of a PC as an intelligent Management terminal connected to the unit's terminal port. When *INPUT CONFIG* is selected from the menu screen, the following message appears:

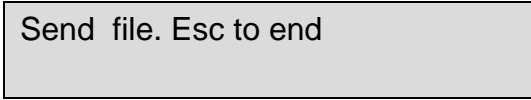

```
Send file. Esc to end
```

Figure 3.18 Input config message screen

3.8.8 Warm start

Selecting *WARM START* simulates turning the mains power off then on again. This may be necessary if a network component hangs up. A warm start does not adversely affect the Emux's configuration parameters, performance statistics database or event log.

3.8.9 Cold start (Caution!)

Selecting *COLD START* returns the Emux's software configuration to the default settings. All configuration parameters will be reset to their defaults, and the performance statistics database and event log will be cleared. The "[nodename]" will be erased, but the real-time clock will not be affected.

For security, you will be asked to confirm this request. Pressing *Y* will perform the cold start, pressing any other key will cancel the request.

Note: This option should only be selected when absolutely necessary, since it may cause disruption to the network.

Operational reasons for needing to *COLD START* include real time clock problems when the RTC must be reset; a change of firmware version number in the Emux owing to carrying out an upgrade; an invalid configuration, probably caused by corruption of the Emux RAM. The management terminal may need to be reset to default settings before you can communicate with the Emux after a cold start.

3.8.10 Event Logs

Event logs are intended to provide a long-term history of major occurrences on the system. They can be the first port of call for a network manager when investigating a problem, and serve to confirm the status of the Emux at any point in time from the last cold start. If a cold start is performed, this log will be cleared and the first entry in the log will be the date and time of that cold start.

EVENT LOGS	
System event log	<display>
Alarm event log	<display>
Config. event log	<display>
Full event log	<display>

Figure 3.19 Event logs

The logs are all accessed from the SYSTEM menu. The logs record the most recent events at the top of the screen, with events sorted into backwards order of time. The log is divided into three separate logs on separate screens: SYSTEM EVENT LOG, ALARM EVENT LOG, CONFIG EVENT LOG and FULL EVENT LOG.

The *SYSTEM EVENT LOG* records system level events

--- System Event Log ---		
16/8/99	23:27:35	power restored
16/8/99	23:19:07	illegal interrupt
15/8/99	00:09:33	power restored
15/8/99	00:09:28	power-down
Press any key to continue		

Figure 3.20 System event log

Note: If the system event log contains either the message *SPURIOUS RESET* or *ILLEGAL INTERRUPT*, please register this occurrence with your Supplier or Distributor of the product. The *ALARM EVENT LOG* records alarms that have arisen since the last cold start. They are recorded simply as MAJOR or MINOR alarms with ON or OFF status.

--- Alarm Event Log ---		
17/2/2001	08:20:23	Major ON POS
16/2/2001	13:21:00	Minor OFF POS
16/2/2001	12:52:38	Minor ON POS
Press any key to continue		

Figure 3.21 Alarm event log

The *CONFIG EVENT LOG* records any configuration changes on the system. This can be very useful since configuration actions may have been taken remotely, without the knowledge of the local user of a node

--- Config Event Log ---		
16/7/2001	08:20:23	Config updated
16/5/2001	13:21:00	Config updated
14/5/2001	11:32:38	Config updated
Press any key to continue		

Figure 3.22 Config event log

<space>	- change value
<enter>	- save new value
<escape>	- exit without saving

Figure 3.23 Testing menu

3.9 Performance data

The subject is described in section 7 of this manual.

3.10 Management menu

From the MAIN SET-UP menu, select the item MANAGEMENT

MANAGEMENT	
Ethernet	<menu>
IP	<menu>
UDP	<menu>
tCp	<menu>
sNmp	<menu>
Telnet	<menu>
Tftp	<menu>
Ping	<menu>

Figure 3.24 Management menu screen

3.10.1 Setting the Unit IP address

To set-up the unit IP address, select the item ETHERNET:

ETHERNET	
State	Down
Phys. address	0:c0:81:0:11:19
DHCP	On
IP addr	0.0.0.0
Net mask	255.255.255.0
Broadcast address	from bit 1
AT table	<display>
sTats	<display>

Figure 3.25 Ethernet default menu screen

To change the IP settings for installation, carry out the following steps:

DHCP For operation in a DHCP enabled network and automatic IP address allocation, leave this parameter ON (ENABLED).

IP address Assign the required IP address for correct installation into the network.

Net mask Assign the required network mask for correct installation into the network. When the IP ADDRESS is changed, the menu screen changes to show the current, or active, IP address as well as the address that will be stored and assumed following a restart.

ETHERNET	
State	UP
Phys. address	0:c0:81:xx:yy:zz
DHCP	Off
IP addr	192.168.0.1
Net mask	255.255.255.0
Broadcast address	from bit 1
AT table	<display>
sTats	<display>

Figure 3.26 Ethernet screen after IP address change

3.10.2 Setting a default route

From the MAIN SET-UP menu, select the item MANAGEMENT and then the IP menu

IP	
default TTL	32
Max reassy time	3 sec
Routing table	<display>
Forwarding	disabled
Stats	<display>

Figure 3.27 IP menu screen

The first two menu items can be set-up by selecting the item and responding to the screen request for data, as shown below:

```
Enter new default Time-to-Live
>
```

Figure 3.28 Default TTL set-up

```
Enter new time in seconds
>
```

Figure 3.29 Maximum reassembly time set-up

The ROUTING TABLE is set -up by selecting the item ROUTING TABLE and following the on-screen instructions to enter data:

Metrodata Emux " "					Alarms: Major
Destination	Next Hop	I/f Type	Prot.	Age	Mask
A - add entry					
D - delete entry					
any other key to exit:					
Add route.					
Destination:					

Figure 3.30 Routing table

Add a new entry to the routing table as a default route as follows:

- Destination: 0.0.0.0
- Mask: 0.0.0.0
- Interface: 1 (Select Ethernet interface)
- Next Hop IP address of Next Hop Router

3.11 Management

In addition to using the terminal port, the Emux may be managed remotely by using a LAN-based network management system. In order to do this a LAN must be connected to the Management port.

The operating parameters, event log, performance statistics database and diagnostics functions are known collectively as the Management Information Base (MIB). The Emux MIB can be accessed remotely by using a Network Management System (NMS) connected to the LAN. The NMS should use SNMP (Simple Network Management Protocol), and could be located on the local LAN or on a remote LAN connected to the local LAN via a LAN bridge or IP router.

The MIB definitions supported have been placed in the public domain by Metrodata and can be parsed in to any NMS supporting an ASN.1 MIB parser. For further information on the management interface and the MIB definition, please refer to the LM1100 SNMP Enabler user manual. The information given in this section is a brief summary to serve as an introduction to the subject.

3.11.1 Management menu

The *MAIN SET-UP* menu contains the option *MANAGEMENT*.

MAIN SET-UP	
G lobal status	<display>
alarm eX tension	<menu>
D ata port set-up	<menu>
V .24 set-up	<menu>
M anagement	<menu>
S ystem	<menu>
T esting	<menu>
P erformance data	<menu>

HIGHLIGHTED letter - select item
<escape> - exit menu

Figure 3.31 Main set-up menu

The *MANAGEMENT* menu leads to a series of menus which permit you to configure the various system management protocols and parameters. Only the utility options *Telnet*, *TFTP* and *PING* are described below. For the other options, please refer to the Metrodata LM1100 manual.

MANAGEMENT	
E thernet	<menu>
I P	<menu>
U DP	<menu>
tC p	<menu>
sN mp	<menu>
T elnet	<display>
tF tp	<menu>
P ing	<display>

HIGHLIGHTED letter - select item
 <escape> - exit menu

Figure 3.32 Management menu

3.11.2 Telnet Option

The Telnet option permits the Emux to operate as a Telnet server.

TELNET	
Timeout	60

Enter no. secs (0 = none)
 >

Figure 3.33 Telnet screens

3.11.3 TFTP

TFTP is used to upload or download software or config files from the device to or from a server (*CLIENT* mode) or to permit remote devices to acquire files from the device (*SERVER* mode). The remote server or device is identified by its *REMOTE IP* address, which is typed into a menu box after the menu item is selected.

TFTP		TFTP	
Mode	Server	Mode	Client
remote IP	192.168.1.10	remote IP	192.168.1.10
Software file name	Emux.45	Get new software	
Config file name	Emux.cnf	get Config	
		Put config	

Figure 3.34 TFTP server & client menu screens

The two modes of TFTP operation are as follows:

a) In *SERVER* mode the device awaits *GET* or *PUT* action from other remote devices. The menu items *SOFTWARE FILE NAME* or *CONFIG FILE NAME* specify the files which can be transferred. Note that Software may only be uploaded into the local device, whilst Config files can be transferred in either direction.

```
Enter file name
>
```

b) In *CLIENT* mode, Config files may be downloaded from the server (*GET*), or may be uploaded to the server (*PUT*). Note that Software may only be uploaded (*GET*) into the local device, whilst Config files can be transferred in either direction. The system requests a file name in response to selection of a *GET* or *PUT* action from the menu.

```
Enter file name, then wait
>
```

3.11.4 Ping

PING is used to check that a selected device is responding on the network by sending a *PING* packet to its IP address, and receiving an acknowledgement if the connection is successful. When *PING* is selected from the screen, the following dialogue occurs if the connection is successful. If it is not, the screen message is *NO RESPONSE*.

```
Metrodata Emux: Local connection to "Emux"
Destination: [192.168.1.10]
press any key to stop test
okay
okay
```

Figure 3.35 Ping screen

3.11.5 SNMP configuration

The Emux must be configured with the details of the SNMP network management station before the unit will generate traps or respond to SNMP polls.

SNMP	
Read community	public
Write community	public
Trap community	public
Managers	<menu>
contact Person	Metrodata Ltd
Node name	xxxxxxx
Output config	<display>
Location	
Stats	<display>
trap Alarms	<menu>

Figure 3.36 SNMP menu screen

3.11.6 Read/Write/Trap communities

Communities are used to control access to the unit via SNMP as a security measure. Separate communities may be configured for Read, Write or Trap access.

3.11.7 Managers

To achieve access to the Emux using SNMP, specific manager addresses must be configured. Once a Manager has been assigned, the Emux will respond to polls and generate traps for that manager. The Emux supports up to 10 configured Network Management Stations. The ADD MANAGER menu is accessed via the MANAGER menu and is shown below:

MANAGERS	
Add manager	public

ADD MANAGER	
IP address	0.0.0.0
Access rights	none
receives Traps	no
Remove managers	<menu>

Figure 3.37 Add manager menu screen

The IP address is the IP address of the assigned Network Management Station.

The Access Rights supported are:

None	No access
Read only	Only SNMP GET access is allowed
Read-Write	SNMP GET/SET access is allowed

The Receive Traps parameter determines whether Traps should be sent to this network Manager under alarm conditions.

3.11.8 Contact person

The contact person is the SNMP MIB-2 **system SysContact** parameter. The default setting is:

Metrodata Limited, Fortune House, Eversley Way, Egham, Surrey TW20 8RY

The parameter may be up to 255 characters and should be defined to reflect the actual installation's characteristics.

3.11.9 Location

The location is the MIB-2 **system SysLocation** parameter. This entry is blank by default. The parameter may be up to 255 characters long, and should be defined to reflect the actual installation's characteristics.

3.11.10 Statistics (Stats)

Metrodata Emux “ “
SNMP Statistics
snmpInPkts
snmpOutPkts
snmpInBadVersions
snmpInBadCommunityNames
snmpInbadCommunityUses
snmpInASNPParseErrs
snmpInTooBig
snmpInNoSuchNames
snmpInBadValues
snmpInreadOnlys
snmpInGenErrs
snmpInTotalReqVars
snmpInTotalSetVars
press any key to continue:

snmpInGetRequests
snmpInGetNexts
snmpInSetRequests
snmpInGetResponses
snmpInTraps
snmpInGetRequests
snmpOutTooBig
snmpOutNoSuchNames
snmpOutBadValues
snmpOutGenErrs
snmpOutGetRequests
snmpOutGetNexts
snmpOutSetRequests
snmpOutGetResponses
snmpOutTraps
press any key to continue:

Figure 3.38 Stats report headings

3.12 Trap alarms

TRAP ALARMS	
Uplink	<menu>
E1 port	<menu>

UPLINK	
0 - LOS	Trap
1 - LOF	Trap
3 - AIS	Trap
4 - RAI	Trap
9 - FB	Trap

Enter port 1 - 16
>

E1 PORT 3	
0 - LOS	Trap
3 - AIS	Trap

Figure 3.39 Trap alarms

Each trap alarm can be toggled to TRAP or NO TRAP status.

4 DATA PORT CONFIGURATION

This section deals with the configuration of each of the user data port types, including E1 and Uplink. A simple configuration will be described for each type of port.

Select the menu item DATA PORT SET-UP from the MAIN MENU screen. The response is shown below:

DATA PORT SET-UP	
Uplink	<menu>
E1	<menu>

Figure 4.1 Data port set-up screen

4.1 Uplink port configuration

The Uplink port config screen is accessed from the DATA PORT SET-UP screen shown above.

UPLINK	
Module type	Dual 1+1 Fibre
SFP1	OC-3 SM IR
SFP2	Not Fitted
Active SFP	None
Auto Fallback	Enabled
sWitchover timeout	5
sCrambler mode	X^43-1
Tx clock Source	Internal Osc.
BERT	<menu>

Figure 4.2 Uplink port menu screen

4.1.1 Module type

This item displays the type of uplink module that has been fitted to the Emux. The display is included to permit future products to be fitted with different types of uplink, such as E3.

Currently the option displayed is : Dual 1+1 Fibre

If only a single SFP is fitted, as shown in the screen above, then manual intervention by toggling the ACTIVE SFP does not result in changeover action.

Note that SFP1 is designated the primary link, and SFP2 is the secondary or Fallback link. When the Fibre switches to using the fallback link, the Emux will generate a Fallback alarm.

4.1.2 SFP1, SFP2 type

This menu item shows the type of SFP module fitted to each port of the Fibre module. Metrodata supply a range of SFP devices that have been tested for operation with the Emux:

OC-3 MM 1310 SR-1	1310 nm, Multi-mode, short range (2km)
OC-3 MM 1310 IR-1	1310 nm, Single-mode, intermediate range (15km)
OC-3 MM 1310 LR-1	1310nm, Single-mode, long range (40km)
OC-3 MM 1310 LR-2	1310nm, Single-mode, long range (80km)

Alternatively, if no SFP is fitted in either port, the screen will show NOT FITTED.

4.1.3 Active SFP select

The ACTIVE SFP SELECT option enables the user to select between automatic switching and forced operation over one fibre or the other. The options are:

AUTO	Automatic switch over on fault occurring
SFP1	Force operation over SFP1 interface, switching disabled
SFP2	Force operation over SFP2 interface, switching disabled

In normal conditions, the AUTO option should be selected. If no SFP2 interface is fitted, the forced operation does not work, and the uplink reverts to the single installed option.

4.1.4 Restore Primary (SFP1)

The Emux designates SFP1 as the primary link. Should a fault occur that forces fallback to the SFP2 link, the Emux raises a FALLBACK minor alarm.

The automatic switching circuit only functions when a fault is detected. It will not automatically restore the primary link. This must be a manual operation after the primary link fault has been cleared.

4.1.5 SFP1, SFP2 status

The SFP status menu item shows the current status of the SFP interfaces. The options are as follows:

ACTIVE	Signal good, Port currently selected
OK	Signal good, Port not currently selected
LOS	Loss of Signal
Not Fitted	SFP not fitted to Emux

4.1.6 Switchover time-out

A time-out is available to prevent link flapping whilst the new link tries to synchronise after a switch over. The time-out period is the length of time following a switch over before switching can occur again. The time-out is configurable from 1 to 31 seconds.

4.1.7 Scrambler mode

To ensure that enough transitions are present on the fibre interface, the data is scrambled before transmission. This ensures that long sequences of 1 or 0 are prevented.

The options are:

X ⁴³ -1	43 bit scrambler
X ³ -1	3 bit scrambler. (Metrodata FC3000 compatible)

The X43 scrambler should be selected unless the Emux is connected to a Metrodata FC3000 unit.

4.1.8 Tx clock source

The correct timing mode must be configured for the Uplink port. The options are:

Internal Osc.	Transmit timing derived from the local oscillator. Accurate to +/- 15ppm
Uplink	Transmit timing is derived from the receive signal
E1 Port xx	Transmit timing is derived from a selected E1 port (xx = port number)

In virtually all applications using the fibre interface, the timing mode should be set to INTERNAL.

4.1.9 Uplink BERT

The Emux offers extensive BERT testing for validation of the uplink. BERT testing enables the transmission and receipt of a range of BERT patterns. The BERT testing is described in further detail in Section 6 of this manual.

4.2 E1 port configuration

The Emux supports 4, 8 or 16 E1 ports operating simultaneously. Each E1 port is independently configured. E1 ports are presented as RJ-45 connectors mounted on the rear panel of the Emux. The port number assignments are shown below:

4	3	2	1
---	---	---	---

Figure 4.3 Emux 4 port layout

8	7	6	5
4	3	2	1

Figure 4.4 Emux 8 port layout

16	15	14	13	8	7	6	5
12	11	10	9	4	3	2	1

Figure 4.5 Emux 16 port layout

To configure an E1 port, select DATA PORT SET-UP from the MAIN MENU screen, then select E1

DATA PORT SET-UP	
Uplink	<menu>
E1	<menu>

Figure 4.6 Data port set-up screen

The system responds with a request to enter the E1 Port number:

Enter port 1-16
>

This leads to the screen below. There are two parameters available for each port. In normal operation, these are left in the default state.

E1 PORT 4	
State	<menu>
Long/Short Haul	
BERT	<menu>

Figure 4.7 E1 port set-up screen

4.2.1 State

The STATE parameter controls the state of the E1 port, which must be UP for normal operation. When a port is not used it should be placed in the DOWN state. This will force the transmission of an AIS (All 1'S) signal both upstream and downstream. When a port is in the DOWN state alarm processing is disabled for that port.

4.2.2 Long haul/Short haul

The E1 interface may be set for either long or short haul operation. For connection to other equipment within the building, the interface should be set to SHORT HAUL.

4.2.3 E1 BERT

The interface offers extensive BERT testing capabilities for validation of the E1 port/line. BERT testing involves transmission and reception of a range of BERT patterns. For more information on this facility, see section 6 of this manual.

5 SNMP MANAGEMENT

The Emux supports SNMPV1 for both read and write access, and in addition will generate unsolicited traps. The Emux must be configured with the IP address of an NMS (Network Management system) before it will generate traps or respond to SNMP polls.

The Emux requires the following MIB's

RFC-1213	MIB-2
METROHDR.MIB	Metrodata Enterprise Definitions
METROMSC.MIB	Metrodata Enterprise Miscellaneous Definitions
METROTRP2.MIB	Metrodata Enterprise Trap Definitions

5.1 MIB-2, sysObjectID

The Emux uses the ID: **Enterprises.503.1.49**

Where:

503 = Metrodata Enterprise MIB (METROHDR)
 1 = MetroSysObjectID
 51 = Emux

5.2 Traps

Traps are unsolicited messages issued when a given condition arises in the product that has to be signalled to the management system without waiting for the device to be polled.

The Emux generates standard traps as per the RFC-1215 as well as the Enterprise Specific traps defined by METROTR2.MIB

Traps on the Emux are all generated using the TRAP-V1 PDU. The METROTR2.MIB utilises the TRAP-TYPE macro as defined in RFC-1215. The Emux issues traps on the occurrence of physical faults on the interfaces.

METROTRP2 is a generic trap database, and as such the interface generating the trap is included in the definition.

5.2.1 Trap Enterprise Field

The Emux will issue traps with the ENTERPRISE field set to:

Enterprises.503.3 Enterprises.metro.metroTraps

5.2.2 Trap Interface Field

The Emux allocates the following ifIndex values:

ifIndex = 1	Internal Management LAN port
ifIndex = 4	Uplink
ifIndex = 5	E1 Port 1
ifIndex = 6	E1 Port 2
ifIndex = 7	E1 Port 3
ifIndex = 8	E1 Port 4
ifIndex = 9	E1 Port 5
ifIndex = 10	E1 Port 6
ifIndex = 11	E1 Port 7
ifIndex = 12	E1 Port 8
ifIndex = 13	E1 Port 9
ifIndex = 14	E1 Port 10
ifIndex = 15	E1 Port 11
ifIndex = 16	E1 Port 12
ifIndex = 17	E1 Port 13
ifIndex = 18	E1 Port 14
ifIndex = 19	E1 Port 15
ifIndex = 20	E1 Port 16

Figure 5.1 Interface Traps

5.2.3 Trap types

The Emux supports the following generic trap types:

Trap Type 1	Warm Start
Trap Type 2	Link Down
Trap Type 3	Link Up
Trap Type 6	Enterprise specific trap

Figure 5.2 Trap types

Other trap types are not supported or generated by the Emux.

5.2.3.1 Generic Trap 1, Warm Start

When the unit powers up and initialises it will issue a single WARM START trap to indicate that the Emux has warm started.

Note that a Cold Start trap is NOT issued since the cold start returns the Emux to its factory default settings with no SNMP manager configured.

5.2.3.2 Generic Trap 2, Link Down

When any of the external ports are in an alarmed state, a LINK DOWN trap will be issued on occurrence of the alarm condition.

For an E1 port, a LINK DOWN trap is issued on detection of either a Loss of Signal (LOS) an AIS condition.

For a Fibre port, a LINK DOWN trap is issued on detection of LOS, LOF or AIS

The generic Link Down Trap contains the ifIndex value to indicate the number of the port that has entered the LINK DOWN state.

5.2.3.3 Generic Trap 3, Link Up

When any of the external ports are not in an alarmed state, a LINK UP trap will be issued on exit from the alarm condition.

For an E1 port, a LINK UP trap is issued when the Loss of Signal (LOS) an AIS condition is cleared.

For a Fibre port, a LINK UP trap is issued when the LOS, LOF or AIS condition is cleared.

The generic Link Down Trap contains the ifIndex value to indicate the number of the port that has returned to the LINK UPstate.

5.2.3.4 Generic Trap 6, Enterprise Specific Trap

Enterprise Specific Trap1	When a port enters the alarmed state i.e. LINK DOWN, the Emux will issue this trap to give more information than the simple LINK DOWN trap
Trap 1 MetroOtherMajorStart	This trap also includes the ifIndex value to indicate the number of the port that has entered the Major Alarm state.
Enterprise Specific Trap 3	When a port exits the alarmed state i.e. LINK UP, the Emux will issue this trap to give more information than the simple LINK UP trap
Trap 3 MetroOtherMajorEnd	This trap also includes the ifIndex value to indicate the number of the port that has exited the Major Alarm state.
Enterprise Specific Trap 2	When a port enters the alarmed state i.e. LINK DOWN, the Emux will issue this trap to give more information than the simple LINK DOWN trap
Trap 2 MetroOtherMinorStart	This trap also includes the ifIndex value to indicate the number of the port that has entered the Minor Alarm state.
Enterprise Specific Trap 4	When a port exits the alarmed state i.e. LINK UP, the Emux will issue this trap to give more information than the simple LINK UP trap
Trap 4 MetroOtherMinorEnd	This trap also includes the ifIndex value to indicate the number of the port that has exited the Minor Alarm state.
Enterprise Specific Trap 13	When the Emux powers up, or warm starts, it will issue this trap to augment the generic WARM START trap.
Trap 13 MetroPowerUp	

6 FAULT FINDING

There are a number of facilities provided on the Emux to help in solving problems that may arise when installing or operating the product. This section provides advice on diagnosing and locating any problems.

6.1 Top level alarm summary

An immediate indication of the current operational state of the Emux is given by the alarm indication on the top right hand side of every menu in the user interface



The Alarms statement can be MAJOR, MINOR or NONE. If alarms are present, further investigation can be made using either the GLOBAL STATUS overview or the performance monitoring display screens.

6.2 Global status overview

The Global status display is accessed by selecting the item GLOBAL STATUS from the MAIN SET-UP menu. The display screen shows the state of every port and tributary on a single screen.

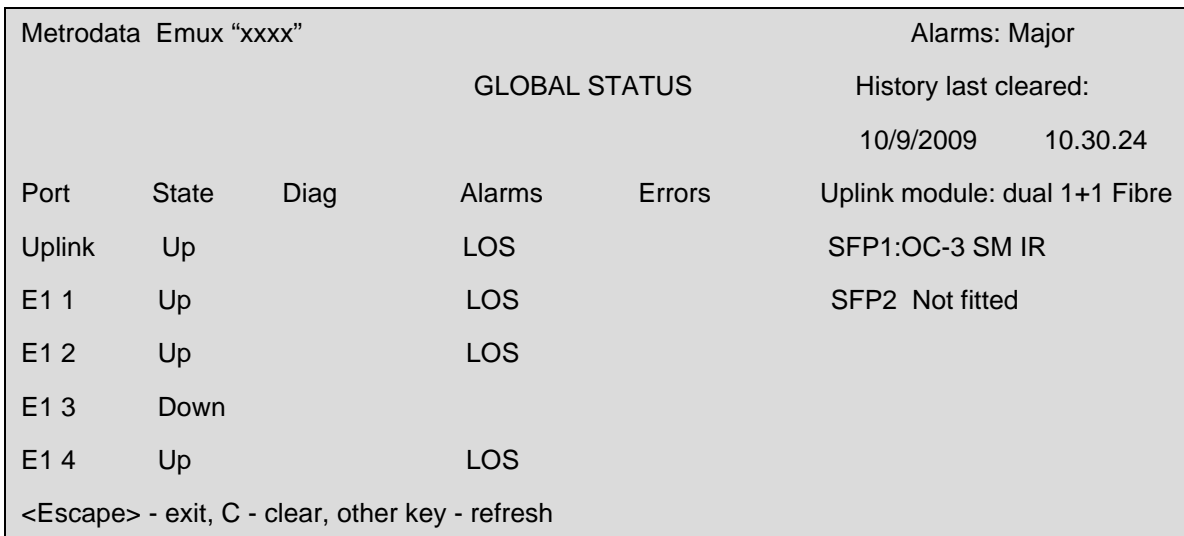

Figure 6.1 Global status display screen

The GLOBAL STATUS shows both current and historic alarms. Current alarms are shown in capital letters, e.g. LOS, meaning that the alarm is currently active. Historic alarms are shown in lower case, e.g. los, meaning that at some time in the past an alarm has arisen. Historic alarms may be cleared by typing [**c**] to clear the history.

A single alarm is displayed for each port, usually the highest priority alarm for that layer. Multiple alarms are often active, and it is necessary then to view the physical layer statistics for that particular port or tributary to identify the full range of alarms.

6.3 Loopbacks

The Emux provides a range of diagnostic loopbacks.

Uplink port	
None	Normal Operation
Local Loop	Fibre Transmit looped back to Fibre Receiver
Outside Loop	Fibre Receive looped back to Fibre Transmit
E1 ports	
None	Normal Operation
Local Loop	E1 Transmit looped back to E1 Receiver
Outside Loop	E1 Receive looped back to E1 Transmit

Figure 6.2 Emux Loopback tests

The schematic below shows the principles of the inside and outside loop tests.

In a Local loop test, a signal for transmission is passed directly back to the receiving port for comparison.

In an Outside loop test, a signal received by the unit's interface is returned to the device transmitting it.

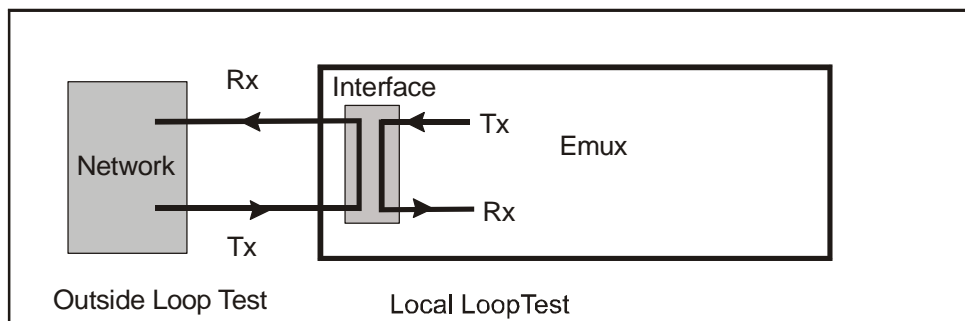

Figure 6.3 Loop test examples

6.4 BERT testing

BERT testing facilities are provided for testing the E1 and/or Uplink circuits. Access is from the MAIN SET-UP menu by selecting DATA PORT SET-UP. The two paths for the interfaces are shown below.

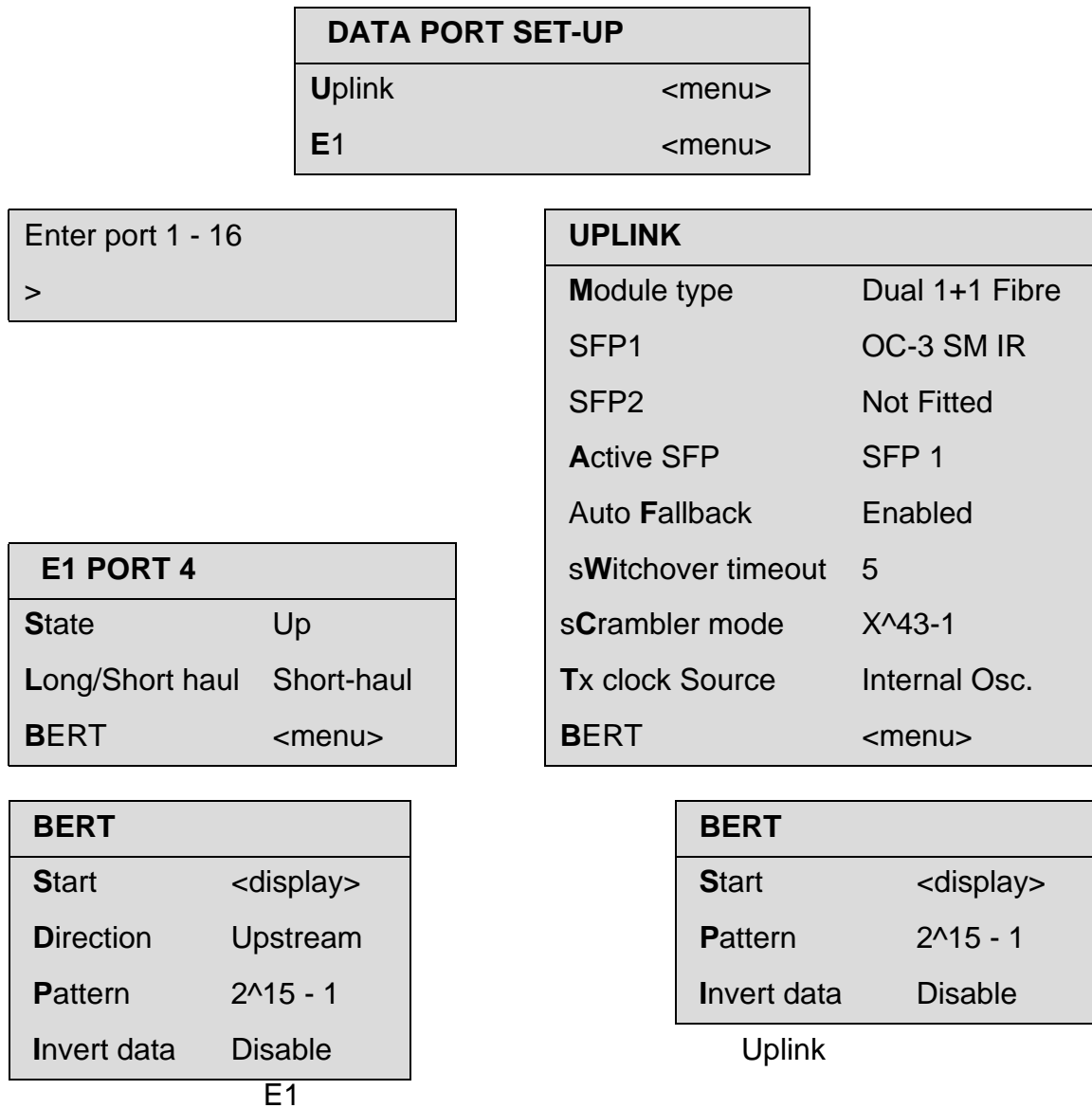

Figure 6.4 BERT test menu sequence for E1 (left) & Uplink (right)

6.4.1 E1 BERT

Direction	Options are Upstream or Downstream. In the Downstream option, the BERT pattern is transmitted internally to replace the received E1 data. In the Upstream option, the BERT pattern is transmitted externally as the E1 Transmit data.
Pattern	Pattern is selectable with full range of 0.151 test patterns available. patterns include: 2 ⁷ - 1, 2 ⁹ - 1, 2 ¹¹ - 1, 2 ¹⁵ - 1, 2 ²⁰ - 1, 2 ²³ - 1, QRSS
Data Invert	For compatibility with external test equipment, data pattern may be sent normally or with inverted data. Select as required.

Figure 6.5 E1 BERT menu

6.4.2 Uplink BERT

The Uplink BERT test is always in the upstream direction.

Pattern	Pattern is selectable with full range of 0.151 test patterns available. patterns include: 2 ⁷ - 1, 2 ⁹ - 1, 2 ¹¹ - 1, 2 ¹⁵ - 1, 2 ²⁰ - 1, 2 ²³ - 1, QRSS
Data Invert	For compatibility with external test equipment, data pattern may be sent normally or with inverted data. Select as required.

Figure 6.6 Uplink BERT menu

6.4.3 Start/Stop test, E1 or Uplink

When the START item is selected the BERT test is started and the results are displayed as below:

Metrodata Emux "xxxx"		Alarms: None
Status:	Out of Sync	
Bit Count	0	
Error Count	0	
BER	0	
<Escape> - exit, C - Clear counts, F - Force Error, S - Stop		

Figure 6.7 BERT results screen

When you press **<esc>** to escape from the display, the system responds with the screen below:

BERT	
Stop	<display>

Figure 6.8 BERT stop screen

When **<S>** is pressed to stop the BERT, the screen reverts to the start screen

BERT		BERT	
Start	<display>	Start	<display>
Direction	Upstream	Pattern	2 ¹⁵ - 1
Pattern	2 ¹⁵ - 1	Invert data	Disable
Invert data	Disable		

Figure 6.9 BERT stop screen response

7 PERFORMANCE

7.1 Performance data

The performance data displays provide complete status for each physical port or tributary within the system. The display maintains a count of errored seconds for each alarm and also displays each currently active alarm.

The Statistics are accessed by selecting PERFORMANCE DATA from the MAIN SET-UP screen. The response screen permits the user to select the interface and display mode

PERFORMANCE DATA	
Interface	E1
Display mode	Static summary
Summary style	G.821
Phys. layer stats	<display>
Error type	BPV Errors
Clear all data	

Figure 7.1 Performance data menu

The first item INTERFACE is toggled between UPLINK and E1. When E1 is selected, the interface number must be specified on the response screen below:

Enter port 1-16

>

The other items DISPLAY MODE, SUMMARY STYLE and ERROR TYPE are all toggled to the required choice. Then pressing <P> causes the statistics screen to be presented.

Note: The item CLEAR ALL DATA empties the database, and therefore a cautionary prompt appears as shown below:

Clears all logged data

Are you sure?

Figure 7.2 Clear all data prompt

7.2 Errors and Alarms

The Emux provides you with extensive performance analysis functions, which allow you to monitor and record service information about the various links. The first part of this section describes the Errors and Alarms that are valid for the modes of operation of the Emux. Performance data is displayed in the form of an on-screen report or summary. Information is grouped into periods of 15 minutes. Examples of the screens are shown in later subsections.

7.2.1 Uplink port alarms & errors

The following alarms are monitored. The default status is shown in the table below in upper case. The alarm extension menu can be used to set the status of any alarm to the required level e.g. MAJOR, Minor or None

0 - LOS	Loss of Signal	MAJOR, Minor, None
1 - LOF	Loss of Frame	MAJOR, Minor, None
2 - LOC	Loss of Clock	MAJOR, Minor, None
3 - AIS	Alarm Indication Signal	MINOR, Major, None
4 - RAI	Remote Alarm Indication	MAJOR, Minor, None
5 - FB	Fall Back Alarm	MAJOR, Minor, None

Figure 7.3 Emux Uplink Alarm types

The following error types are reported:

BPV	Bi Polar Violation
FAS	Frame Alignment Signal
CRC-4	Cyclic Redundancy Check
PRBS	Pseudo Random Binary Sequence
REBE	Remote End Block Error

Figure 7.4 Emux Uplink Error types

7.2.2 E1 port alarms & errors

The following alarms are signalled. The default status is shown in the table below in upper case. The alarm extension menu can be used to set the status of any alarm to the required level e.g. MAJOR, MINOR or NONE. The only error reported is the BPV error.

0 - LOS	Loss of Signal	MAJOR, Minor, None
3 - AIS	Alarm Indication Signal	MINOR, Major, None
BPV Errors	Bi Polar Violation errors	

Figure 7.5 Emux Alarms & errors

The definitions corresponding to Performance reporting are given below:

Alarms		Definition
LOS	Uplink, E1	Loss Of Signal: No data and therefore no clocking information. The units are alarm seconds if the summary style is G.821, or events if the style is set to counts.
LOF	Uplink	Loss of Frame: Clocking information is there but the frame alignment pattern is faulty. The units are alarm seconds if the summary style is G.821, or events if the style is set to counts.
AIS	Uplink, E1	Alarm Indication Signal: All '1s' being received. The units are alarm seconds if the summary style is G.821, or events if the style is set to counts.
RAI	Uplink,	Far End Receive Failure: the remote Emux has detected a problem. The units are seconds if the summary style is G.821, or events if the style is set to counts.
FB	Uplink,	Fall back alarm
Errors	Interface	Definition
BPV	Uplink, E1	Bi Polar Violation
FAS	Uplink	Frame Alignment Signal, indicating a fault in the frame alignment pattern
CRC-4	Uplink	Cyclic Redundancy Check indicating data integrity errors although frame alignment has been maintained.
PRBS	Uplink	Indicates that an error has been received in the Test Pattern detector.
REBE	Uplink	Remote End Block Error indicates that the far end device has detected a CRC-4 error.
G.821 Errors		Definition
Err. Count		The number of errors in the interval.
Total secs		Valid number of seconds in the interval (less than 900 means that the 15- min. period was incomplete).
EFS		Error-free seconds.
ES		Errored seconds: seconds with an error.
BES		Bursty errored seconds: seconds ≥ 2 errors, < 1 in 10^3 errors
SES		Severely errored seconds: seconds > 1 in 10^3 errors.
UAS		Unavailable seconds: declared after SES for 10 consecutive secs.
DM		Degraded minutes: > 1 in 10^6 errors/minute.

The sample screen below shows a typical Performance Summary screen for an Uplink.

Metrodata Emux: " "		Alarms: Major		
13:32:54 Mon 18/10/2010		PERFORMANCE SUMMARY		Uplink
Current Alarms: LOS		-----		Diag: None
	Temporary	Current	Previous	Last
	Counts	15 mins	15 mins	24 hours
Alarmed secs				
Total Secs	856	510	900	2400
LOS	856	510	900	2400
LOF	0	0	0	0
AIS	0	0	0	0
RAI	0	0	0	0
BPV Errors:				
Total secs	856	510	900	0
ES	0	0	0	0
SES	0	0	0	0
UAS	856		900	0
<Escape> - exit, N - next interface, C - clear temp, other key - refresh				

Figure 7.6 Typical Performance summary screen

Note: The temporary count column on display can be cleared without affecting the main 24-hour statistics.

7.3 Performance menu

PERFORMANCE DATA	
Interface	E1 port 2
Display mode	Static summary
Summary style	G.821
Phys layer stats	<display>
Error type	BPV errors
Clear all data	

HIGHLIGHTED letter – select item <escape> - exit menu
--

<space> - change value <enter> - save new value <escape> - exit without saving
--

Figure 7.7 Performance data menu

7.3.1 Interface

This field is for the selection of the interface for which statistics are to be displayed. Options are toggled using the space bar. They are: *Uplink* or *E1*. If E1 is selected, a response screen requests the identity number of the port to be monitored.

Enter port 1-4>

Figure 7.8 E1 port selection

7.3.2 Display mode

This sets the type of display and the options are:

Full report and Rolling report

Static summary, Updated summary and 15 minute summaries

These modes are described in the subsections below describing reports and summaries. Reports and summaries are dealt with separately since they have different characteristics.

7.3.3 Summary style

The *SUMMARY STYLE* menu option only appears when a Summary has been selected (as opposed to a Report) from the Display mode menu item, and this is therefore described in section 7.5.3 below.

7.3.4 Physical layer stats

This item leads to the physical layer stats display screen described later in this section.

7.3.5 Error type

The Error type to be reported is selected by toggling the options presented on the menu screen. The options are described in section 7.2.1 and 7.2.2 above.

7.4 Physical layer stats – Reports

7.4.1 Full Report

This presentation gives six sequential screens of information extending over the previous 24 hours for each type of error. The entries show the performance statistics for each 15-minute interval, referenced from the current real-time clock time.

Note: If the real-time clock is altered then the relative times of this database are also modified

Metrodata Emux: “ “							Alarms: Major					
Uplink							1 of 6					
BPV Errors:							Alarmed seconds:					
Period Starting	Count	Valid	EFS	ES	SES	UAS	Valid	LOS	LOF	AIS	RAI	FB
14:09:23	0	900	0	0	0	0	900	900	0	0	0	
14:24:23	0	900	0	0	0	0	900	900	0	0	0	
14:39:23	0	900	0	0	0	0	900	900	0	0	0	
14:54:23	0	900	0	0	0	0	900	900	0	0	0	
15:09:23	0	900	0	0	0	0	900	900	0	0	0	
15:24:23	0	900	0	0	0	0	900	900	0	0	0	
15:39:23	0	900	0	0	0	0	900	900	0	0	0	
15:54:23	0	900	0	0	0	0	900	900	0	0	0	
16:09:23	0	900	0	0	0	0	900	900	0	0	0	
16:24:23	0	900	0	0	0	0	900	900	0	0	0	
16:39:23	0	900	0	0	0	0	900	900	0	0	0	
16:54:23	0	900	0	0	0	0	900	900	0	0	0	
17:09:23	0	900	0	0	0	0	900	900	0	0	0	
17:24:23	0	900	0	0	0	0	900	900	0	0	0	
17:39:23	0	900	0	0	0	0	900	900	0	0	0	
17:54:23	0	900	0	0	0	0	900	900	0	0	0	

<Escape> to exit, other key - more

Figure 7.9 Full report screen

7.4.2 Rolling report

The *Rolling report* option gives a single line summary of the statistics at the end of each 15-minute period. This option is a more economic version of the *15-minute summaries* option where a line printer is used, since only one report line is added to the printout every 15 minutes.

Metrodata Emux: " "							Alarms: Major					
Uplink Interface												
BPV Errors:							Alarmed seconds:					
Period Starting	Count	Valid	EFS	ES	SES	UAS	Valid	LOS	LOF	AIS	RAI	FB
14:09:23	0	900	0	0	0	0	900	900	0	0	0	
14:24:23	0	900	0	0	0	0	900	900	0	0	0	
14:39:23	0	900	0	0	0	0	900	900	0	0	0	
14:54:23	0	900	0	0	0	0	900	900	0	0	0	
15:09:23	0	900	0	0	0	0	900	900	0	0	0	
<Escape> to exit												

Figure 7.10 Rolling report screen

7.5 Physical layer stats - Summaries

7.5.1 Screen presentation

The summary report screens are designed to give a view of the alarm and error status on a single screen. There is a choice of update frequencies of the data so that the user can choose the optimum presentation at any time.

The type of Alarm or Error being monitored is shown in the left hand column of the screen. Always check this when viewing a screen for the first time. If a diagnostic test is being run, its name appears at the top right of the screen entitled *DIAGS*.

The *Temporary counts* column is used to obtain error counts over a user definable test period, the duration of which need not be time related to anything else, without erasing the entire statistics database. You can reset the *Temporary counts* by pressing *C*. This means that a measurement may be started after a 15 minute interval has partly elapsed. The counts are displayed for the temporary measurement period from its start until you clear it down by pressing **<c >**.

Pressing any key other than **<c>** or **<esc>** will instantly refresh the display. This applies to each of the display styles - *Static*, *Updated* and *15 minute* displays.

The *Current 15-mins* column gives the error counts for the current partial 15 minute period. Therefore the duration of statistics within this column varies between 0 and 15 minutes in a cyclical fashion as time passes.

The *Previous 15-mins* column gives the error counts for the previous complete 15 minute period, assuming that there has been one.

The *Last 24 hours* column gives the error counts for the previous 24-hour period, as an accumulation of the last 96 complete *Previous 15-mins* periods.

7.5.2 Presentation display modes

The three *DISPLAY MODES* for summaries define the frequency with which the display data is updated.

Static summary

This option presents the data as a single screen display, giving a snapshot of the current status. The information in the display may be updated by pressing any key except **<escape>**.

Updated summary

This is similar to a static summary except that the screen is refreshed approximately every 5 seconds, and provides a dynamic display of events.

15 minute summaries

This updates the information in a summary at the end of each 15 minute period. This mode is useful where a printer is connected to the terminal port and a detailed log is required.

Once one of these summary types has been selected for display, three styles of display are available for selection, as described below.

7.5.3 Summary style

This option determines the method of presenting the error information in the summaries. These options are not available for the full or rolling reports, which have a fixed style. The *SUMMARY STYLE* option only shows on the menu when a *SUMMARY* has been selected in the *DISPLAY MODE*. The styles available are:

Counts	Errors and alarms accumulate and are quoted as an absolute count.
G.821	Errors and alarms are expressed as G.821 parameters per second.
% G.821	Errors and alarms are shown in terms of normalised percentage G.821 parameters.

Figure 7.11 Summary styles

7.5.4 Summary display - COUNTS style

Metrodata Emux: " "		Alarms: Major		
13:32:54 Mon 18/10/2010		PERFORMANCE SUMMARY		Uplink
Current Alarms: LOS		-----		Diag: None
	Temporary	Current	Previous	Last
	Counts	15 mins	15 mins	24 hours
Alarmed secs				
Total Secs	856	510	900	2400
LOS	856	510	900	2400
LOF	0	0	0	0
AIS	0	0	0	0
RAI	0	0	0	0
BPV Errors				
Total secs	856	0	0	0
Err Count	0	0	0	0
Error rate	0	0	0	-
<Escape> - exit, N - next interface, C - clear temp, other key - refresh				

Figure 7.12 Performance summary screen - COUNTS style

Note:

If an alarm appears in Counts style, it appears only once as a single event, and is recorded in the Temporary Counts column only. It may be best to confirm an alarm situation by setting the summary screen to G.821 style when an alarm is present.

7.5.5 Summary display - G.821 style

Metrodata Emux: " "		Alarms: Major		
13:32:54 Mon 18/10/2010		PERFORMANCE SUMMARY		Uplink
Current Alarms: LOS		-----		Diag: None
	Temporary	Current	Previous	Last
	Counts	15 mins	15 mins	24 hours
Alarmed secs				
Total Secs	856	510	900	2400
LOS	856	510	900	2400
LOF	0	0	0	0
AIS	0	0	0	0
RAI	0	0	0	0
BPV Errors:				
Total secs	856	510	900	0
ES	0	0	0	0
SES	0	0	0	0
UAS	856		900	0
<Escape> - exit, N - next interface, C - clear temp, other key - refresh				

Figure 7.13 Performance summary screen - G.821 style

Note:

If an alarm appears in G.821 style, it is updated incrementally in the Temporary Counts and other columns as appropriate for its duration. The definition of G.821 as parameters per second gives a different summary layout than that for Counts style. In Counts style, an event is recorded once only.

7.5.6 Summary display - Percent G.821 style

Metrodata Emux: " "		Alarms: Major		
13:32:54 Mon 18/10/2010		PERFORMANCE SUMMARY		Uplink
Current Alarms: LOS -----		Diag: None		
	Temporary	Current	Previous	Last
	Counts	15 mins	15 mins	24 hours
Alarmed secs				
Total Secs	36543	510	900	0
%LOS	99.998%	100.0000%	100.0000%	0.0000%
%LOF	0.0000%	0.0000%	0.0000%	0.0000%
%AIS	0.0000%	0.0000%	0.0000%	0.0000%
%RAI	0.0000%	0.0000%	0.0000%	0.0000%
BPV Errors:				
%EFS	0.0000%	0.0000%	0.0000%	0.0000%
%ES	0.0000%	0.0000%	0.0000%	0.0000%
%SES	0.0000%	0.0000%	0.0000%	0.0000%
%UAS	100.0000%	100.0000%	100.0000%	0.0000%
<Escape> - exit, N - next interface, C - clear temp, other key - refresh				

Figure 7.14 Performance summary screen - Percent G.821 style