

## APPLICATION NOTE

Variable speed leased lines up to 16 Mbps – Comparison of existing methods using the CMUX versus Metrodata Fractional STM1 service delivery

- Single service delivery from 2 to 16Mbit/s instead of multiple E1 leased lines.
- Multiple applications can be broken out by a single router
- Less customer-sited equipment
- Reduced costs in CPE and line tariffs
- Automatically upgradeable bandwidth

Carrier Division



## Application Opportunity

Leased line services are not generally available between E1 speed at 2Mbit/s and E3 speed at 34Mbit/s (or DS3 at 45Mbit/s). Consequently, a tariff and bandwidth step-function exists when needing to expand above 2Mbit/s.

Typically, a need for a speed increase from 2Mbit/s can be to 4 or 6Mbit/s or other speeds up to 16Mbit/s. The choice currently is to use multiple-E1 services, which is complex and costly, or using an E3/DS3 with unused capacity!

Where multiple applications, or medium bandwidth single applications, are delivered to the same site, multiple leased lines will be used. Result: a termination unit and interface converter, plus a router or other data terminal for each leased line.

A clear opportunity exists, therefore, for single service delivery solution with associated saving on tariffs, equipment costs and space.

Carrier Division



## Metrodata Solution

The existing methods used by the carriers to pass multiple E1 leased lines for a medium bandwidth (up to 16 Mbit/s) application to a customer site are expensive and complicated. This entails using the Cmux product from Marconi and an Imux from other companies.

A new development from Metrodata enables medium bandwidth services to be delivered over a fractional STM1 leased line via fibre optic cable. The new product incorporates an SDH multiplexer and an Inverse multiplexer I-mux in a single unit. This potentially allows delivery of the equivalent  $n \times E1$  services for a scaleable 'leased line' between two sites at speeds of between 2 and 16 Mbit/s over an SDH network – filling that current huge gap between 2 and 34Mbit/s.

This application note describes the new facility for medium bandwidth service delivery between two customer sites. The diagram on the following page shows the general application.

The Metrodata units provide a physical link between the sites via an SDH network. The protocol passed between the Routers at both sites can be IP or Frame Relay. The Metrodata unit uniquely aggregates the 'virtual' bandwidth from the STM-1 SDH service to that required by the user – between 2Mbit/s and 16Mbit/s. Single routers will then break out the specific information applications.

Both X21 and HSSI customer interfaces are supported. The Routers used by the customer at either site can be low end products e.g. Cisco 1605 with a single X.21 interface suitable to work at speeds up to 8 Mbit/s. Work at rates up to 16 Mbit/s then the router must be upgraded to HSSI (High Speed Serial Interface) e.g. Cisco 3620.

The Metrodata Unit brings together Inverse Multiplexer functionality with line interface and signal conversion from fibre to X21 or HSSI. It offers a single flexible service delivery for multiple applications and used with single on-site routers save the associated costs of multiple leased-lines. It will also automatically respond to changes in bandwidth supplied from the core SDH network – allowing very easy automatic changes to service speeds for the customer.

So, extending the STM1 interface to a customer site via fibre to then Inverse Multiplex the Virtual Containers into the required bandwidth makes both technical and commercial sense.

The Metrodata solution to this problem is to design and manufacture a product that connects to a standard SDH multiplexer over single mode fibre fractional STM1 link. The customer receives and pays for the bandwidth he *actually* needs.



## Figure 1 - Medium Bandwidth Service Provision

### The Current Way

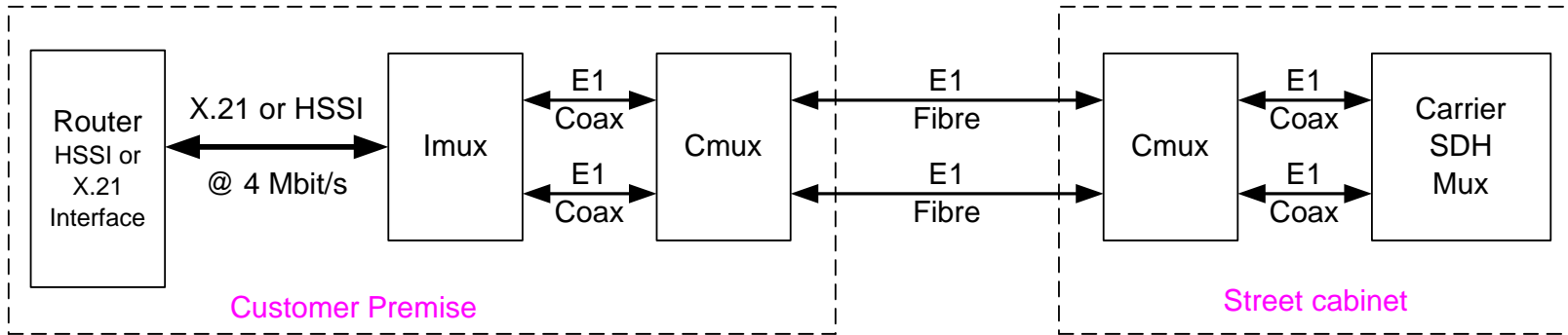

### The Metrodata Way

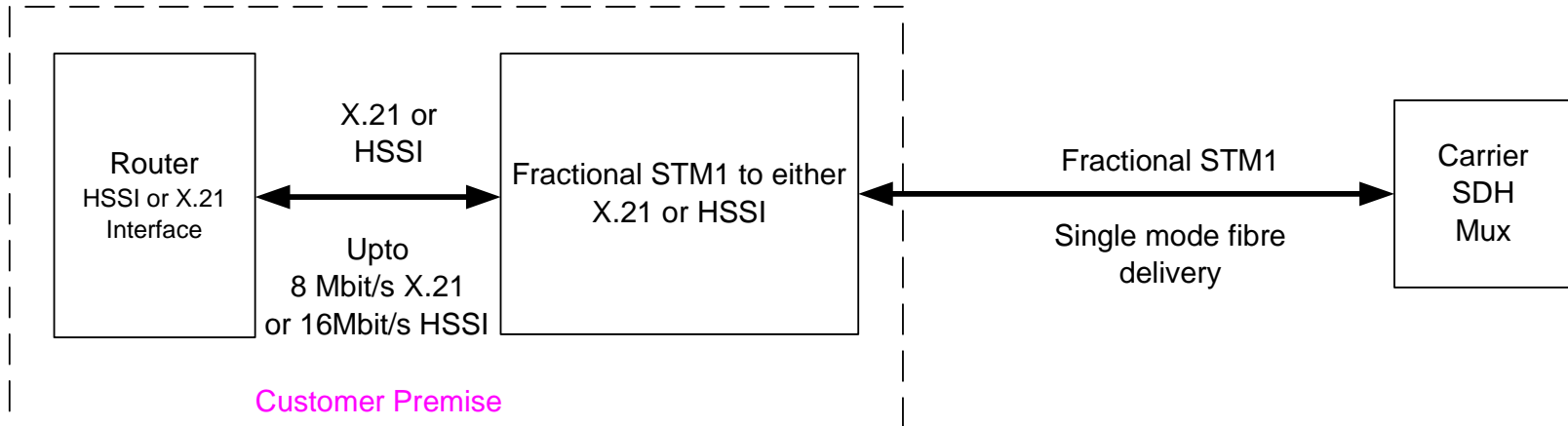

Carrier Division



## Technical Overview of SDH infrastructure

SDH constitutes the core of the new all-digital very high bandwidth networks, based upon an STM1 frame that can carry a number of 'virtual containers'. These STM1 frames are then transported over single mode fibre between the SDH multiplexers.

Each SDH multiplexer can access individual virtual containers and pass these to a line card that converts the virtual container to a recognised leased line speed e.g. E1, E3 or DS3.

An SDH multiplexer does not have on board fibre drivers for E1, E3 or DS3, but does have a fibre driver for an STM1 signal, to which the Metrodata unit can connect via fibre cable. External equipment such as the Cmux can provide fibre drivers for E1 service delivery.

Most leased line Service Providers have SDH core networks and this innovative development from Metrodata facilitates an earlier rollout of SDH capacity attracting new revenue, whilst also satisfying an important Customer need.

Carrier Division



## Metrodata Overview – a technically excellent British communications company

You think you have an issue connecting communications equipment and network services together? – Not any more - Metrodata will have developed the solution to your current need, and we are already developing the solutions for your future needs!

The communications world is full of techno-terminology and mystique. Convergence, fibre, SDH, STM1, ATM, integration, copper, interface conversion, interface extension, coaxial, dsu, satellite, broadband, connectivity, access, standards and so on.

Carriers and Service Providers are coming under increasing pressure from the market to provide more than just leased lines. End to end management of their services, fast service provision, flexible bandwidth and tariffing, remote management and diagnostic tools are some examples.

Be assured the **Metrodata Carrier Division** is working closely with users and SP's to create innovative solutions and services.

**Metrodata are the experts to guide you to your network solution.**

---

## Contact Details

For further information regarding this Applications please contact the Carrier Division Team.

Email: [sales@metrodata.co.uk](mailto:sales@metrodata.co.uk)

Tel: +44 (0) 1784 744 700

Fax: +44 (0) 1784 744 730

Alternatively visit our Website at <http://www.metrodata.co.uk/>



Carrier Division

