

DC2000

User
Manual

www.metrodata.co.uk

Metrodata DC2000 User Manual

Metrodata Ltd
Fortune House
Crabtree Office Village
Eversley Way
Egham
Surrey TW20 8RY
United Kingdom

tel: +44 (0) 1784 744700
fax: +44 (0) 1784 744730
email: support@metrodata.co.uk
website: www.metrodata.co.uk/support

Part No: 76-02-012N

Metrodata Ltd

No part of this publication may be reproduced, transmitted, transcribed, stored in a retrieval system, or translated into any language or computer language, in any form or by any means, electronic, mechanical, magnetic, optical, chemical, manual or otherwise, without the prior written permission of

Metrodata Ltd,
Fortune House,
Crabtree Office Village,
Eversley Way,
Egham, Surrey, TW20 8RY,
United Kingdom.

Tel: +44 (0) 1784 744700

Fax: +44 (0) 1784 744730

e-mail: support@metrodata.co.uk

www: <http://www.metrodata.co.uk>

ftp: <ftp://ftp.metrodata.co.uk>

Disclaimer

Metrodata Ltd makes no representations or warranties with respect to the contents hereof and specifically disclaims any implied warranties or merchantability or fitness for any particular purpose. Further, Metrodata Ltd reserves the right to revise this publication and to make changes from time to time in the content hereof without obligation of Metrodata Ltd to notify any person of such revision or changes.

Trademarks

The Trademarks of other Corporations which may be used in this manual are hereby acknowledged.

Copyright © 2004 by Metrodata Ltd
All Rights Reserved

1	INTRODUCTION	1
1.1	Performance	1
1.2	Safety	1
1.3	Electromagnetic Compatibility	1
1.4	EN55022 Declaration	1
1.5	FCC Declaration	1
1.6	DC2000 Typical Installation	2
1.7	Signal Transmission	3
1.8	Payload	3
1.9	Power Supply	3
2	DC2000 DESCRIPTION OF PARTS	4
2.1	Front Panel	4
2.2	Rear Panels	4
2.3	Power Supply	6
2.4	Older DC2000 Models	7
2.5	EIA-530 DTE Port	8
2.6	EIA-530 TO RS-449 Connector Cable	9
2.7	EIA-530 TO X.21 Connector Cable	10
2.8	V.35 DTE-Port	11
2.9	X.21 DTE Port	12
2.10	X.21 to EIA-530 Converter cable	13
2.11	X.21 TO RS-449 Converter Cable	14
2.12	Unbalanced Network Port (BNC)	15
2.13	Balanced RJ45 Network Port	15
2.13.1	Connecting to a terminal device	16
2.13.2	Connecting to a network device	16
2.13.3	RJ45 Connector layout	17
2.13.4	Cable lengths and types	17
3	DC2000 INSTALLATION & SET-UP	18
3.1	Installing	18
3.2	Connections	18
3.3	Configuring DC2000	19
3.3.1	E1 LINE Port	19
3.3.2	DCD Status	19
3.3.3	Timing	19
3.3.4	Bit-switches	20
3.3.5	Date & Time	20
3.3.6	Clock Invert	20
3.3.7	Data Invert	21
3.3.8	Unit Clocking	21
3.3.9	E1 Port Alarm Conditions	21
3.3.10	Clocking diagram	22
4	TEST & TROUBLESHOOTING	23
4.1	Remote Loop	23
4.2	Local Loop	24
4.3	Remotely Activated Local Loop	24
4.4	Troubleshooting	25
5	DC2000 SPECIFICATIONS	26
5.1	DC2000 Product specification	26
5.2	Glossary	27

1 INTRODUCTION

The DC2000 DSU (Data Service Unit) is used to interface between an E1 (2.048 Mbps) service and a DTE interface. The DTE interface may be an EIA-530, V.35 or X.21, depending upon the options chosen at the time of purchase of the unit.

Applications include the connection of bridge/routers or multiplexers to high-speed E1 services. In addition to providing interfacing capabilities the DC2000 provides diagnostic facilities for link management in conjunction with the DTE. It can perform local and remote loopbacks. By using line statistics yielded from the DTE, an indication of line performance may be obtained.

1.1 Performance

The DC2000 is approved to OTR.001 and EN41003 and has a port defined as 5C (Unstructured operation). The DC2000 allows connection to the public 2.048 Mbps network presented with a G.703 interface. The DC2000 should not be connected to cabling which would be required by BS6701 to be equipped with over-voltage protection. The worst case delay through the DC2000 is 6 microseconds, and the worst case round trip delay is 24 microseconds.

1.2 Safety

The E1 LINE and DTE ports are designated SELV (Safety Extra Low Voltage) within the scope of EN41003. These ports should only be connected to SELV ports on other equipment in accordance with EN60950 clause 2.3.

1.3 Electromagnetic Compatibility

In order to ensure EMC compliance all signal and data cables and connectors must use a screened connector shell with a screened cable. The cable screen must be terminated to the screened connector shell and not connected to any pins of the connector. If you have selected the V.35 DTE option you should use a Positronic EMC/RFI connector. Positronic connector part numbers are:

Part Number	Max Cable Diameter (mm)
VCMT 34M00P0Y60	7.62
VCMT 34M00P0Y70	9.53
VCMT 34M00P0Y80	11.43

Figure 1.1 Positronic connector part numbers

1.4 EN55022 Declaration

The DC2000 is a Class A product. In a domestic environment it may cause radio interference in which case the user may be required to take adequate measures.

1.5 FCC Declaration

This equipment has been tested and found to comply with the limits for a Class A digital device, pursuant to Part 15 of the FCC Rules. These limits are designed to provide reasonable protection against harmful interference when the equipment is operated in a commercial environment. This equipment generates, uses, and can radiate radio frequency energy and, if not installed and used in accordance with the instruction manual, may cause

harmful interference to radiocommunications. Operation of this equipment in a residential area is likely to cause harmful interference in which case the user will be required to correct the interference at its own expense.

1. 6 DC2000 Typical Installation

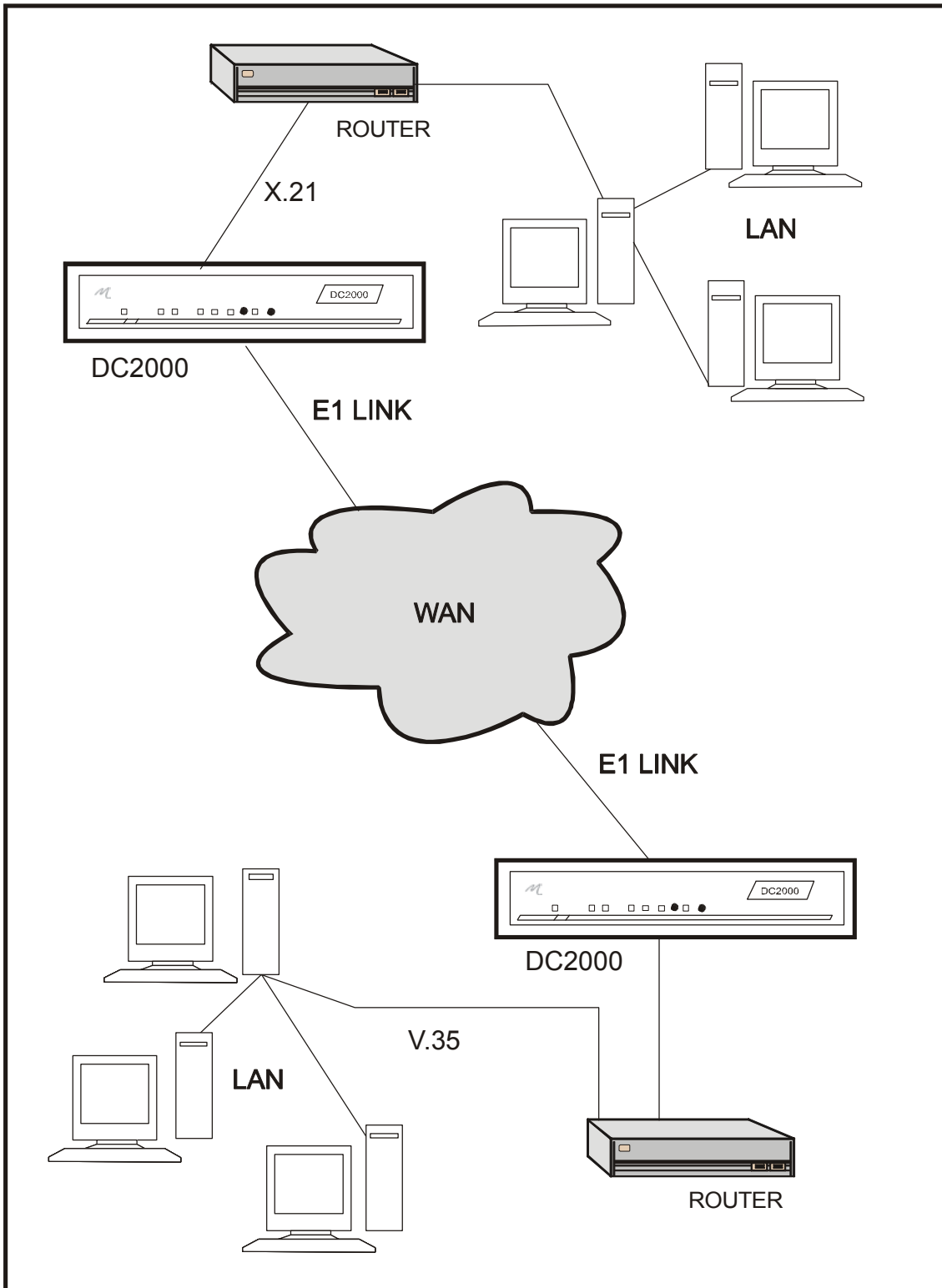

Figure 1.2 DC2000 Deployment

1. 7 Signal Transmission

The DC2000 is used on unstructured E1/G.703 digital services. The transmission rate is 2.048 Mbps. The signal is transmitted on 75 Ohm RG59 unbalanced coax with BNC connectors or 120 Ohm balanced coax / twisted pairs with RJ45 connectors. The signal has alternate mark inversion (AMI) characteristics in accordance with G.703. A mark is transmitted as a 0.5 unit interval (UI) wide pulse of amplitude 2.37V (75 Ohm) or 3V (120 Ohm). Alternate marks have opposing polarity so that '111' is transmitted as a positive pulse, a negative one and then another positive one.

The pulses have a duration of 50% so that strings of '1's can be identified as a series of pulses. This is because clocking information is derived from the transmitted signal. In addition, strings of zeros are replaced with HDB3 (High-Density Binary 3) code words to ensure pulse density (and therefore clocking information) and an average DC potential of 0V.

1. 8 Payload

The DC2000 operates with a DTE port data rate of 2.048 Mbps. Data from the DTE is carried on the E1 aggregate as unstructured payload.

1. 9 Power Supply

The DC2000 is powered by an internal mains-fed power supply.

For current models of the DC2000, which have a white fascia panel, the input voltage ranges are:

Either	110-117V/60Hz fused at 500mA.
Or	220-240V/50Hz fused at 250mA

Selection of the DC2000 input power supply voltage is achieved via a switch on the back of the unit. The DC2000 is provided ex-factory with a 250mA fuse for 240 volt mains supply. If you are connecting to 110 volt mains, you should exchange the fuse for a 500mA one. This equipment must be connected to mains safety earth for correct operation.

The input power consumption of the DC2000 is approximately 4 watts. Therefore with an input voltage of 220 VAC, it consumes approximately 20 mA. With an input voltage of 110 VAC, it consumes approximately 40 mA.

Note: Older models with a black front fascia panel do not have a fuse holder, nor do they offer a choice of mains supply voltage. They are 240V only. Figure 2.4 shows the rear panel of the older DC2000 units.

The DC2000 power supply should be connected to a supply socket that is physically located close to the DC2000 and is easily accessible.

Safety Note:

Excessive voltages are present inside the unit. There are no user serviceable parts inside the unit, and the cover should not be removed by unqualified personnel. The unit must not be exposed to damp or condensing conditions.

2 DC2000 DESCRIPTION OF PARTS

2.1 Front Panel

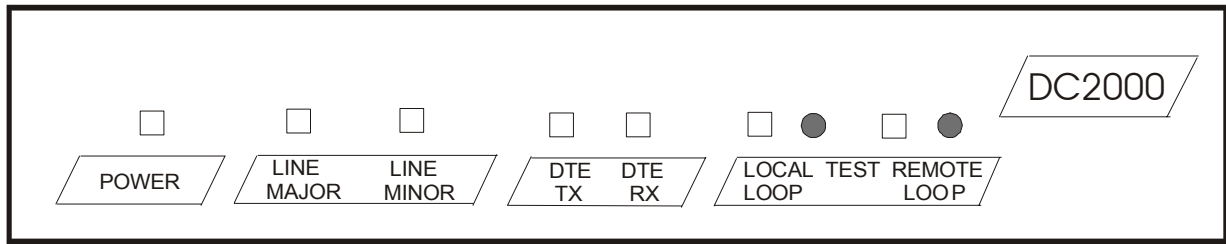

Figure 2.1 DC2000 front panel

The schematic above shows the DC2000 front panel indicator lights and test switches. Note that the test switches operate in the same way as the re-set button on a PC – one push/release operates the switch.

The DC2000 provides you with essential information through a series of LED's on the front panel. The colour of some of these LED's will depend on the type of data that is being handled at the time, and these are described in the table below. All connections into and out of the DC2000 are made through the rear panel.

LED	Colour	Meaning
Power	Red	Mains power is being received.
Line:		
Major Minor	Red Yellow	LOS alarm is present. AIS alarm is present.
DTE		
TX Data and RX Data	Red Green Orange	Data being transmitted or received = 1 Data being transmitted or received = 0 The data is switching rapidly between 0 and 1.
Test		
Local loop Remoteloop	Yellow Yellow	The E1 line port has been looped locally or the remote LOOP UP pattern has been received. The remote LOOP UP pattern has been sent.

Figure 2.2 DC2000 Front panel alarms

2.2 Rear Panels

The rear panel layout for recent models with white fascia panels is shown in Figure 2.3 below. Both 240VAC mains powered and -48VDC powered units are shown. Older units with black fascia panels have a different layout of the bit-switches A, B, C & D, as shown in Figure 2.4. Note that the figures show bit-switches as being labelled with their identifying letter. They are not in fact labelled on the rear of the unit.

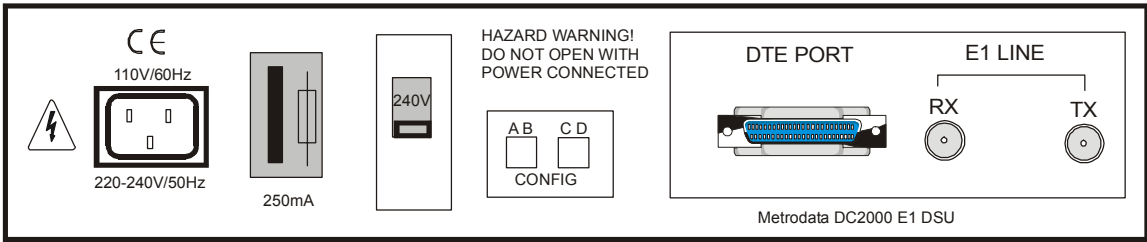

EIA530/BNC layout

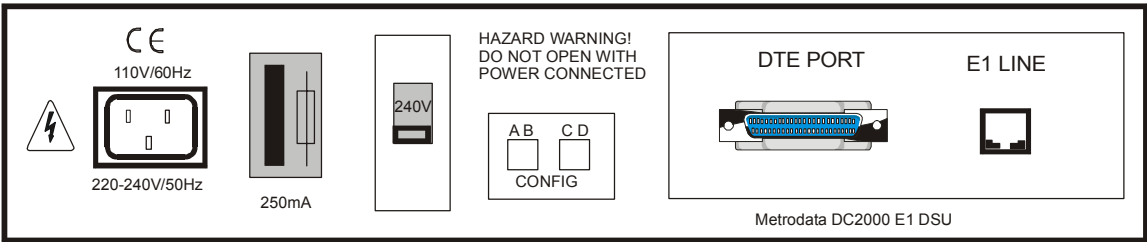

EIA530/RJ45 layout

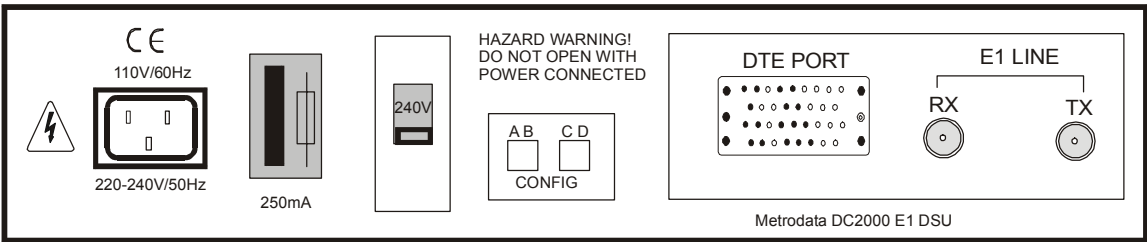

V.35/BNC layout

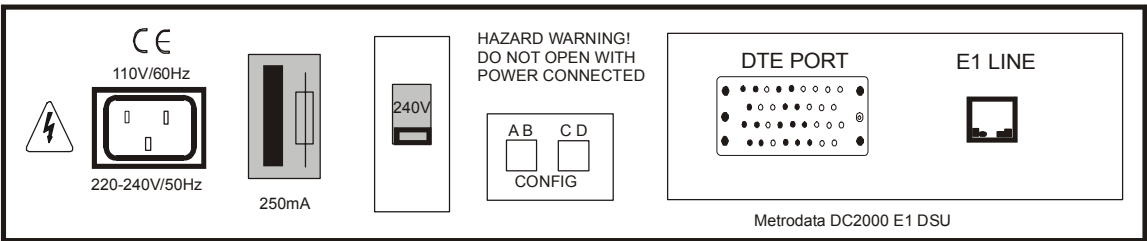

V.35/RJ45 layout

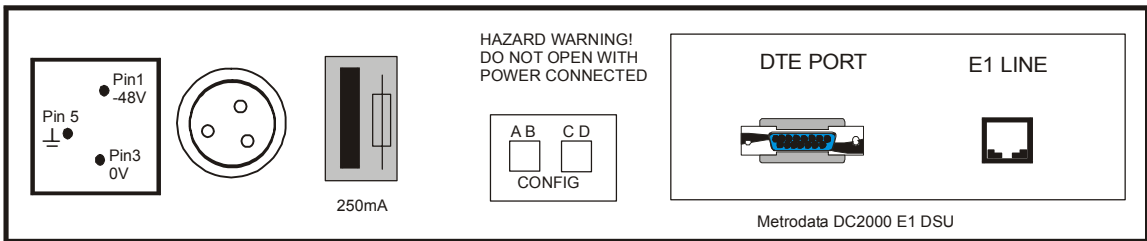

-48VDC power supply, X.21/RJ45 layout

Figure 2.3 DC2000 Rear panel layouts

2. 3 Power Supply

Mains power is connected to the IEC inlet on the rear of the unit. The unit is shipped wired for 240V operation. To convert from 240V to 110V, change the switch setting on the back of the unit, and exchange the 250mA fuse for a 500mA fuse.

The -48VDC unit has a Buccaneer type socket, and the unit is shipped with a male plug for fitting onto Customers' own wiring. The DC voltage range is -36 to -72 VDC, fused at 500mA.

The DC2000 is powered by an internal mains-fed power supply.

For current models of the DC2000, which have a white fascia panel, the input voltage ranges are:

Either 110-117V/60Hz fused at 500mA.

Or 220-240V/50Hz fused at 250mA

Selection of the DC2000 input power supply voltage is achieved via a switch on the back of the unit. The DC2000 is provided ex-factory with a 250mA fuse for 240 volt mains supply. If you are connecting to 110 volt mains, you should exchange the fuse for a 500mA one. This equipment must be connected to mains safety earth for correct operation.

The input power consumption of the DC2000 is approximately 4 watts. Therefore with an input voltage of 220 VAC, it consumes approximately 20 mA. With an input voltage of 110 VAC, it consumes approximately 40 mA.

Note: Older models with a black front fascia panel do not have a fuse holder, nor do they offer a choice of mains supply voltage. They are 240V only. Figure 2.4 shows the rear panel of the older DC2000 units.

The DC2000 power supply should be connected to a supply socket that is physically located close to the DC2000 and is easily accessible.

Safety Note: Excessive voltages are present inside the unit. There are no user serviceable parts inside the unit, and the cover should not be removed by unqualified personnel. The unit must not be exposed to damp or condensing conditions.

Note: The DC2000 must be connected to mains safety earth for correct operation.

2. 4 Older DC2000 Models

Older models with a black fascia panel do not have the facility to change their mains supply voltage, and are set to 240V operation. There is no rear panel fuse holder on these models. Note that the bit-switches are positioned differently on the rear panel of older models.

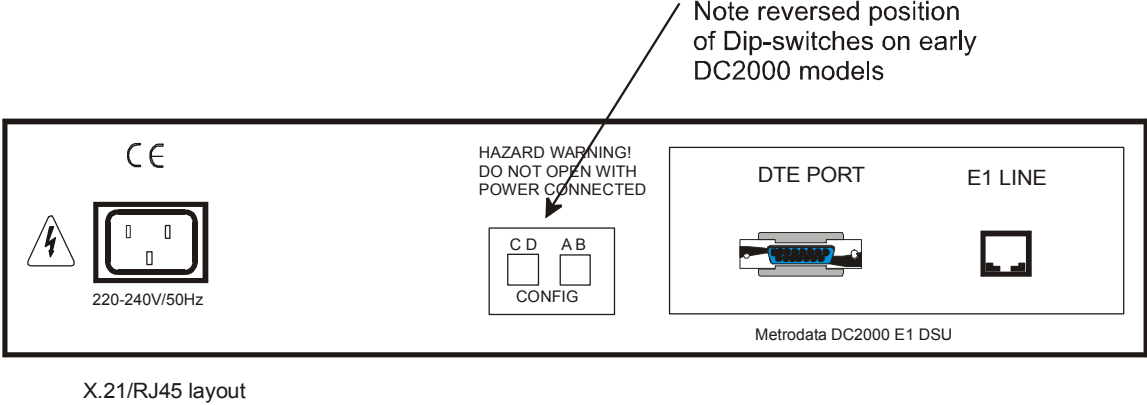

Figure 2.4 Older DC2000 rear panel layout

2. 5 EIA-530 DTE Port

The EIA-530 DTE port is equipped with a female 25-way D-type connector. The panel outlet connections are as follows:

Pin	Function	CCT No
1	Chassis	101
2	T	103
3	R	104
4	RTS	105
5	CTS	106
6	Not connected	
7	Ground	102
8	DCD	109
9	RT(B)	115
10	DCD(B)	109
11	TT(B)	113
12	ST(B)	114
13	CTS(B)	106
14	T(B)	103
15	ST	114
16	R(B)	104
17	RT	115
18	Not connected	
19	RTS(B)	105
20	DTR	108.2
21	Not connected	
22	Not connected	
23	DTR(B)	108.2
24	TT	113
25	Not connected	

Figure 2.5 DTE EIA-530 Port layout

Note: The EIA-530 port is regarded as a SELV port within the scope of EN41003.

2. 6 EIA-530 TO RS-449 Connector Cable

To convert between EIA-530 and RS-449 a simple converter cable may be used. The EIA-530 DTE port is equipped with a female 25-way D-type connector. The connections are as follows:

EIA-530 Pin	Signal		RS-449 Pin
	Function	CCT No	
25 way D Male			37 way D Female
1	Chassis	101	1
2	T	103	4
3	R	104	6
4	RTS	105	7
5	CTS	106	9
6	Not connected		
7	Ground	102	19,20,37
8	DCD	109	13
9	RT(B)	115	26
10	DCD(B)	109	31
11	TT(B)	113	35
12	ST(B)	114	23
13	CTS(B)	106	26
14	T(B)	103	22
15	ST	114	5
16	R(B)	104	24
17	RT	115	8
18	Not connected		
19	RTS(B)	105	25
20	DTR	108.2	12
21	Not connected		
22	Not connected		
23	DTR(B)	108.2	30
24	TT	113	17
25	Not connected		

Figure 2.6 EIA-530 to RS-449 conversion table

2.7 EIA-530 TO X.21 Connector Cable

To convert between EIA-530 and X.21 a simple converter cable may be used as shown below. The EIA-530 DTE port is equipped with a female 25 way D-type connector. The connections are as follows:

EIA-530 Pin	Signal		X.21 Pin
	Function	CCT No	
25 way D Male			15 way D Female
1	Chassis	101	1
2	T	103	2
3	R	104	4
7	Ground	102	8
8	DCD	109	5
9	RT(B)	115	13
10	DCD(B)	109	12
11	TT(B)	113	14
14	T(B)	103	9
16	R(B)	104	11
17	RT	115	6
20	DTR	108.2	3
23	DTR(B)	108.2	10
24	TT	113	7
4, 5, 6, 12, 13, 15, 18, 19, 21, 22, 25	Not connected		15

Figure 2.7 EIA-530 to X.21 conversion cable

2. 8 V.35 DTE-Port

The V.35 DTE port is equipped with a female 34 pin connector, per ISO 2593. The pins that are connected are listed in the table below:

Pin	Function	Definition	CCT No.
A	Chassis	Chassis ground	101
B	Ground	Signal ground	102
C	RTS	Request to send	105
D	CTS	Clear to send	106
E	DSR	Data set ready	107
F	CD	Carrier detect	109
H	DTR	Data terminal ready	108.2
P	Tx(A)	Transmit data(A)	103
R	Rx(A)	Receive data(A)	104
S	Tx(B)	Transmit data(B)	103
T	Rx(B)	Receive data(B)	104
U	XClk(A)	Terminal timing(A)	113
V	RxCIk(A)	Receive timing(A)	115
W	XClk(B)	Terminal timing(B)	113
X	RxCIk(B)	Receive timing(B)	115
Y	TxCIk(A)	Transmit timing(A)	114
AA	TxCIk(B)	Transmit timing(B)	114

Figure 2.8 V.35 DTE Port layout table

Note: The V.35 port is regarded as a SELV port within the scope of EN41003.

2.9 X.21 DTE Port

The X.21 DTE port is equipped with a 15 way female D-type connector in accordance with ISO 4903. The connections are shown below.

Note: The X.21 port is regarded as a SELV port within the scope of EN 41003.

Pin No	Function	Definition	CCT No.
1	Chassis	Shield	101
2	Tx(A)	Transmit (A)	103
3	C(A)	Control (A)	107
4	Rx(A)	Receive (A)	104
5	I(A)	Indication (A)	109
6	S(A)	Signal timing (A)	115
7	X(A)	DTE Signal timing (A)	113
8	Ground	Ground	102
9	Tx(B)	Transmit (B)	103
10	C(B)	Control (B)	107
11	Rx(B)	Receive (B)	104
12	I(B)	Indication (B)	109
13	S(B)	Signal timing (B)	115
14	X(B)	DTE Signal timing (B)	113
15	Not connected		

Figure 2.9 X.21 port connector layout

2. 10 X.21 to EIA-530 Converter cable

To convert between X.21 and EIA-530 a simple converter cable may be used. The layouts are shown below.

X.21	SIGNAL		EIA530
15 way D Male	Function	CCT No	25 way D Female
1	Chassis	101	1
2	Tx(A)	103	2
3	C(A)	108.2	20
4	Rx(A)	104	3
5	I(A)	109	8
6	S(A)	115	15, 17
7	X(A)	113	24
8	Ground	102	7
9	Tx(B)	103	14
10	C(B)	108.2	23
11	Rx(B)	104	16
12	I(B)	109	10
13	S(B)	115	9, 12
14	X(B)	113	11
15	Not connected		4,5,6, 13, 18,19, 21,22,25

Figure 2.10 X.21 to EIA-530 conversion cable

2. 11 X.21 TO RS-449 Converter Cable

To convert between X.21 and RS449 a simple converter cable may be used. The connections are shown below:

X.21 15 way D Male	SIGNAL		RS449 37 way D Female
	Function	CCT No	
1	Chassis	101	1
2	Tx(A)	103	4
3	C(A)	108.2	12
4	Rx(A)	104	6
5	I(A)	109	13
6	S(A)	115	5,8
7	X(A)	113	17
8	Ground	102	19,20,37
9	Tx(B)	103	22
10	C(B)	108.2	30
11	Rx(B)	104	24
12	I(B)	109	31
13	S(B)	115	23,26
14	X(B)	113	35
15	Not connected		2,3,7,9,10,11,14,15, 16,18, 21,25,27,28, 29,32,33,34,36

Figure 2.11 X.21 to RS-449 conversion cable

2. 12 Unbalanced Network Port (BNC)

Pin	Function
Tip	Signal
Ring	Shield

Figure 2.12 BNC connection

Cable lengths should be restricted to those defined below:

Cable	Max. Length (metres)
UR202	720
RG59U	600
BT2002	670
BT2003	690

Figure 2.13 BNC cable lengths

2. 13 Balanced RJ45 Network Port

The layout of the female RJ45 network port mounted on the rear panel is shown below:

Pin	Function
1	Tx tip
2	Tx ring
3	Tx shield
4	Rx tip
5	Rx ring
6	Rx shield
7	Not connected
8	Not connected

Figure 2.14 RJ45 network port layout

2 . 13. 1 Connecting to a terminal device

A connecting cable from the network port to a terminal port such as a router or a PABX is straight through. Connections are defined in the table below.

DSU port pin	DSU port function	Terminal port pin	Terminal port function
1	Tx tip	1	Rx tip
2	Tx ring	2	Rx ring
3	Tx shield	3	Rx shield
4	Rx tip	4	Tx tip
5	Rx ring	5	Tx ring
6	Rx shield	6	Tx shield
7	Not connected	Not connected	Not connected
8	Not connected	Not connected	Not connected

Figure 2.15 Connection from DSU to terminal device

2 . 13. 2 Connecting to a network device

A connection from the network port to a network device such as an E1 line or an NTU requires a crossover cable. Connections are defined in the table below.

DSU port pin	DSU port function	Network port pin	Network port function
1	Tx tip	4	Rx tip
2	Tx ring	5	Rx ring
3	Tx shield	6	Rx shield
4	Rx tip	1	Tx tip
5	Rx ring	2	Tx ring
6	Rx shield	3	Tx shield
7	Not connected	Not connected	Not connected
8	Not connected	Not connected	Not connected

Figure 2.16 Connection from DSU to network device

2 . 13. 3 RJ45 Connector layout

Figure 2.17 shows both the plug and socket head on so that any connecting wires are behind the connector. The connector numbering is shown.

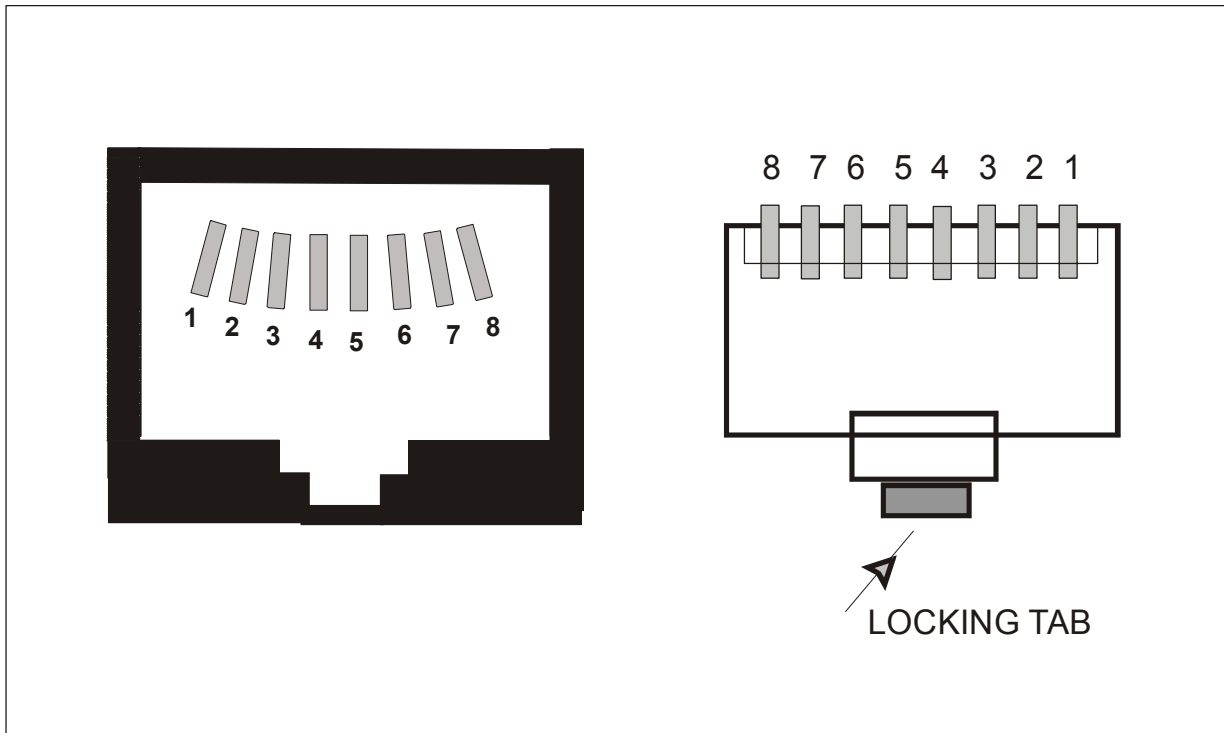

Figure 2.17 RJ45 layout

2 . 13. 4 Cable lengths and types

Cable lengths should be restricted to those defined below:

Cable	Max Length (metres)
Belden 8132 (28 AWG)	175
Belden 9841 (24 AWG)	300

Figure 2.18 Cable lengths

Note: The total maximum attenuation of the cable attached to the network port must not exceed 6dB when measured at 1.024 MHz. The frequency/attenuation characteristic of the cables attached to the network port shall follow a root frequency law. This port type is approved to CTR12, CTR13.

3 DC2000 INSTALLATION & SET-UP

This Section describes how to install and configure the DC2000 ready for use.

3.1 Installing

Safety Notice: Ports that are identified as SELV in this manual should only be connected to SELV ports on other equipment in accordance with EN60950 clause 2.3.

3.2 Connections

Step 1: Mounting.

The DC2000 is housed in a convenient 1U table-top enclosure.

Step 2: DTE

Connect the DC2000 to the DTE, as shown below. The DSU should ideally be placed close to the DTE, with no more than 2m of cable connecting the two.

Note: Your DC2000 will have one of the following DTE connectors:

- a 25-way D-type EIA-530 connector
- a 34 pin V.35 connector
- a 15-way D-type X.21 connector

Use the rear panel diagrams in Figure 2.3 to assist you in identifying which type is fitted on your DC2000.

Step 3: WAN

Note: Before connecting the network port, make sure you have read the connection information in Sections 2.12 and 2.13.

Step 4: Power Supply

Warning: Do not connect the DC2000 to excessive voltages. Read the safety information in Section 1 before continuing.

Finally, check that the correct mains voltage has been set on the rear panel switch, then connect the mains power lead and re-check all connections for security. Turn on the power supply. Check the front panel alarm lights, and refer to Section 2.1 to identify their function, and Section 4 if any of these are illuminated as alarms.

3.3 Configuring DC2000

3.3.1 E1 LINE Port

No configuration of the E1 LINE port is required. The parameters used are:

Parameter	Value
Line coding	HDB3
Framing	Unframed

Figure 3.1 Line port set-up

3.3.2 DCD Status

The DCD signal reflects the state of the E1 signal alarm status. If the E1 LOS Alarm (Loss Of Signal - MAJOR alarm) is active then DCD Data Carrier Detect [or Indication(A) for X.21] is *NOT ASSERTED* (logic low). Otherwise it is *ASSERTED* (logic high).

Some routers monitor the DCD line and will disable the transmission of data when DCD is *NOT ASSERTED*.

3.3.3 Timing

The source for the E1 transmit clock is determined by the settings of the Bit-switches found on the back panel of the unit. The switches are called A, B, C and D from left to right respectively as viewed from the back.

Switch settings are: **UP = OFF**

Note: The normal (default) setup for these Bit-switches is:

ON = ALL DOWN

Once the network is up and running fine tuning of clocking can be done. Timing options are *RECEIVE*, *INTERNAL* and *DTE TIMING*:

With <i>RECEIVE</i> timing the E1 transmit clock is timed from the E1 receive clock.
--

With <i>INTERNAL</i> timing the E1 transmit clock is timed from an internal oscillator.

With <i>DTE TIMING</i> the E1 transmit clocked is timed from the DTE circuit 113 clock. In this case the DTE clock must be accurate to ± 50 ppm of 2.048MHz.
--

Figure 3.2 DC2000 timing options

If *RECEIVE SIGNAL* timing is used on one unit, then the other unit must operate in *INTERNAL* or *DTE* modes.

Bit-switch C	Bit-switch D	Mode
ON or OFF ⁽¹⁾	OFF (UP)	DTE Clock (CCT 113)
OFF (UP)	ON (DOWN)	Internal
ON (DOWN)	ON (DOWN)	Receive signal

Figure 3.3 Bit-switch C & D Settings

Note (1): The switch position is immaterial in this mode.

3 . 3 . 4 Bit-switches

Your DC2000 has either a black or white front fascia panel. The bit-switches are positioned differently for each type as shown below:

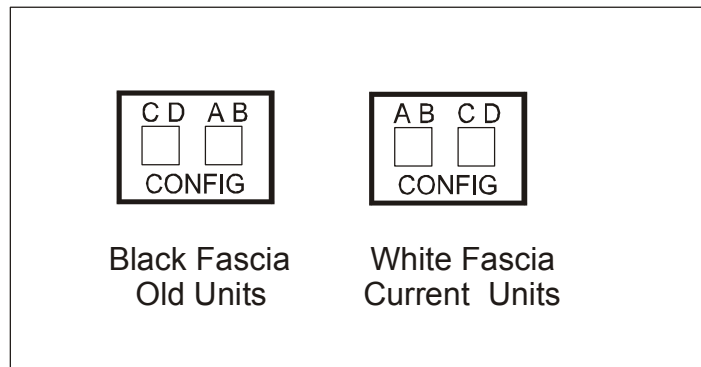

Figure 3.4 Bit-switch positioning

The instructions for setting the switches are the same for each type of unit.

3 . 3 . 5 Date & Time

The DC2000 does not store dates in its memory.

3 . 3 . 6 Clock Invert

The polarity of the Transmit Timing clock edge with which data is loaded in to the DC2000 may be inverted by the use of the Clock Invert Bit-switch. This facility is for use with very long cable lengths and should not normally be used.

Bit-switch A	Mode
ON (DOWN)	Normal
OFF (UP)	Inverted

Figure 3.5 Bit-switch A settings

3 . 3. 7 Data Invert

The polarity of the data transmitted may be inverted by using the Data Invert Bit-switch. This facility is not recommended in normal use.

Bit-switch B	Mode
ON (DOWN)	Normal
OFF (UP)	Data Inverted

Figure 3.6 Bit-switch B settings

3 . 3. 8 Unit Clocking

The clocking regime that is employed in the DC2000 is shown in Figure 3.8. If the units are not being used with X.21 connections to the DTE's then the valid timing modes are as follows:

Internal-Internal
Internal-Rx
DTE-DTE
DTE-Rx

If used with X.21 connections to the DTE's, the only valid timing modes are:

Internal-Rx
DTE-DTE
DTE-Rx

3 . 3. 9 E1 Port Alarm Conditions

In the presence of an alarm condition on the E1 port the following responses are established:

Alarm	Response	Definition
LOS	MAJOR alarm lamp lights <i>DCD NOT ASSERTED</i>	No data is being received at the E1 interface.
AIS	MINOR alarm lamp lights	The DC2000 is receiving 'all 1's' at its E1 interface from a device on the network.

Figure 3.7 E1 Port alarms

Where *LOS* is the Loss Of Signal Alarm and *AIS* is the Alarm Indication Signal.

3 . 3. 10 Clocking diagram

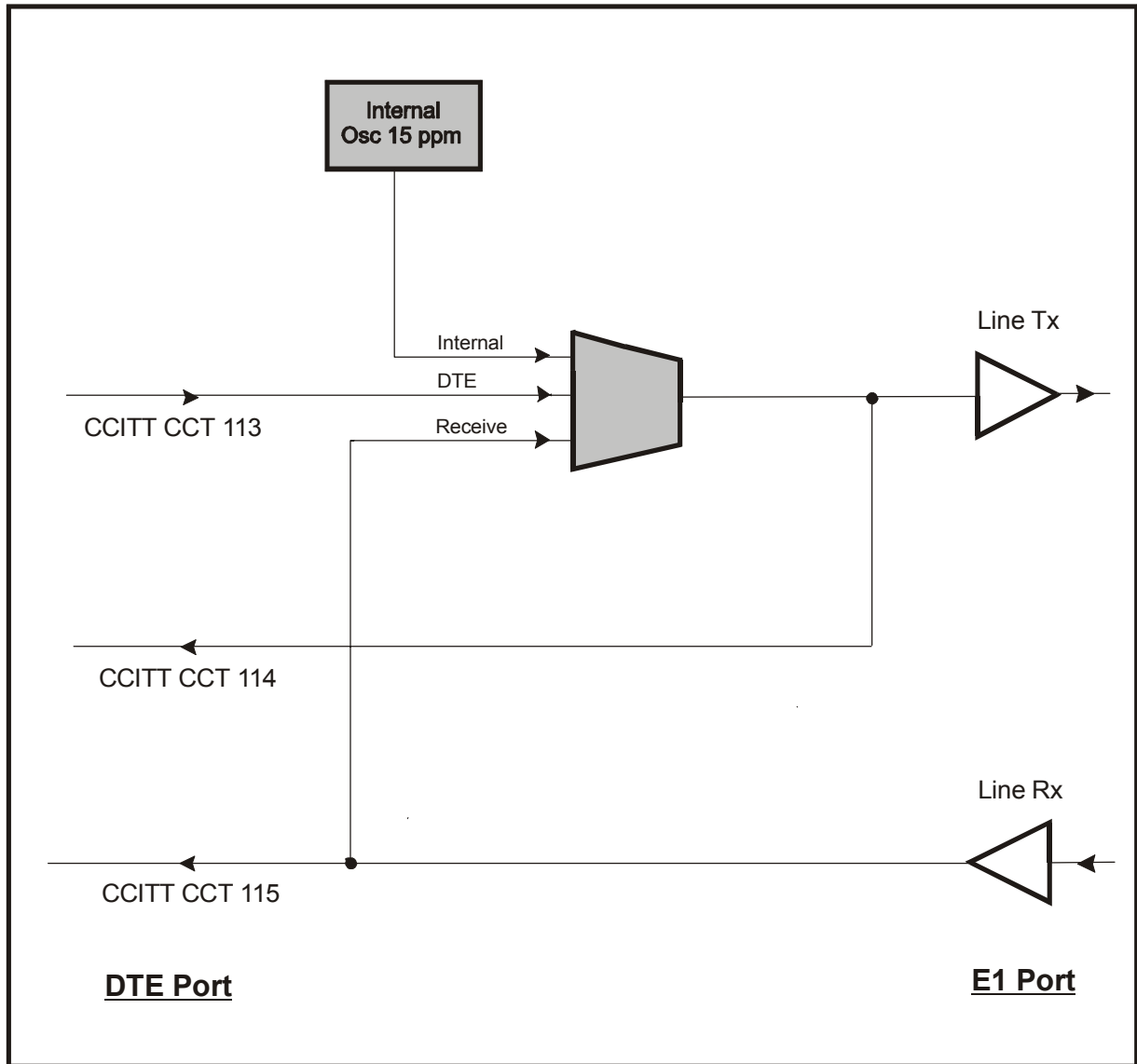

Figure 3.8 DC2000 Clocking diagram

4 TEST & TROUBLESHOOTING

The diagnostics described in this section may be used to identify the source of a transmission problem.

4.1 Remote Loop

A remote loop-back may be performed at the far end without the need for maintenance staff to attend the site.

Remote Loop is activated by pressing the front panel push-button labelled *REMOTE LOOP*. The associated LED then lights to indicate that the test activation sequence has been started (transmitted as repeated '10000' pattern). The loop-activate signal is transmitted to the far end DC2000 for five seconds. After receiving the signal for 4.5 seconds the remote unit will go in to *LOOP*.

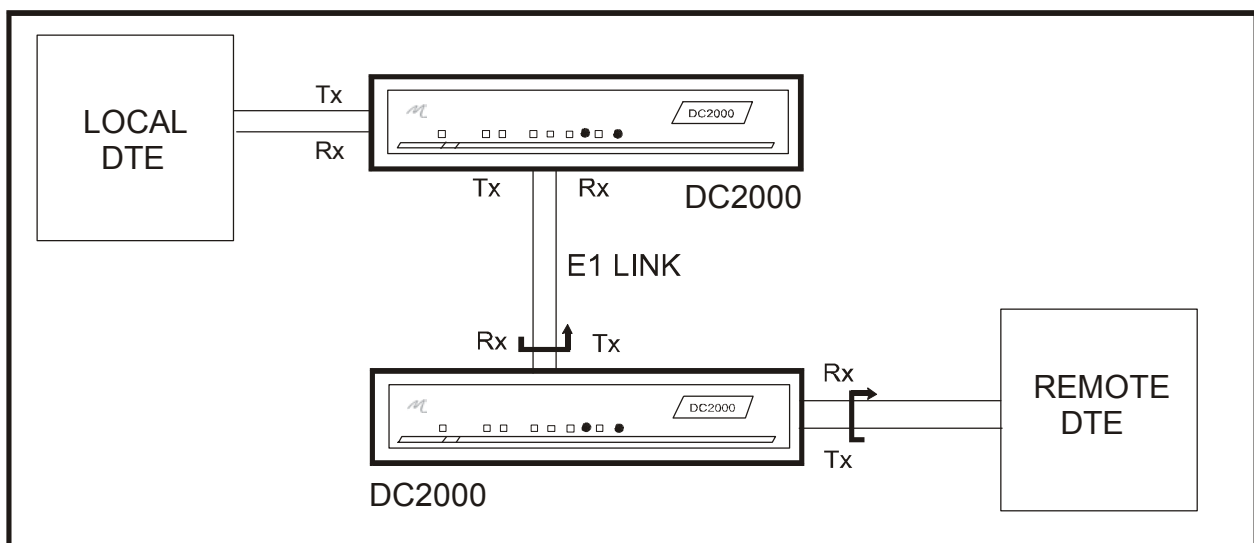

Figure 4.1 Remote loop test

When the E1 Remote Loop is activated the signal received from the E1 port is passed directly back to the link at the line interface. The signal from the DTE is looped adjacent to the DTE port.

This therefore validates:

- (a) the remote DTE cable if the remote DTE recognises its own transmissions.
- (b) the local DTE cable, the local DC2000 and the E1 link if the local DTE recognises its own transmissions.

Pressing the *REMOTE LOOP* push-button again sends the loop-down code for five seconds (transmitted as repeated '100' pattern) at the end of which the *REMOTE LOOP* LED will be extinguished. After 4.5 seconds the far end unit will deactivate the remote loop and its *LOCAL LOOP* LED will be extinguished.

4.2 Local Loop

Local Loop is activated by pressing the front panel push-button labelled *LOCAL LOOP*. The associated LED then lights to indicate that the loop is operating.

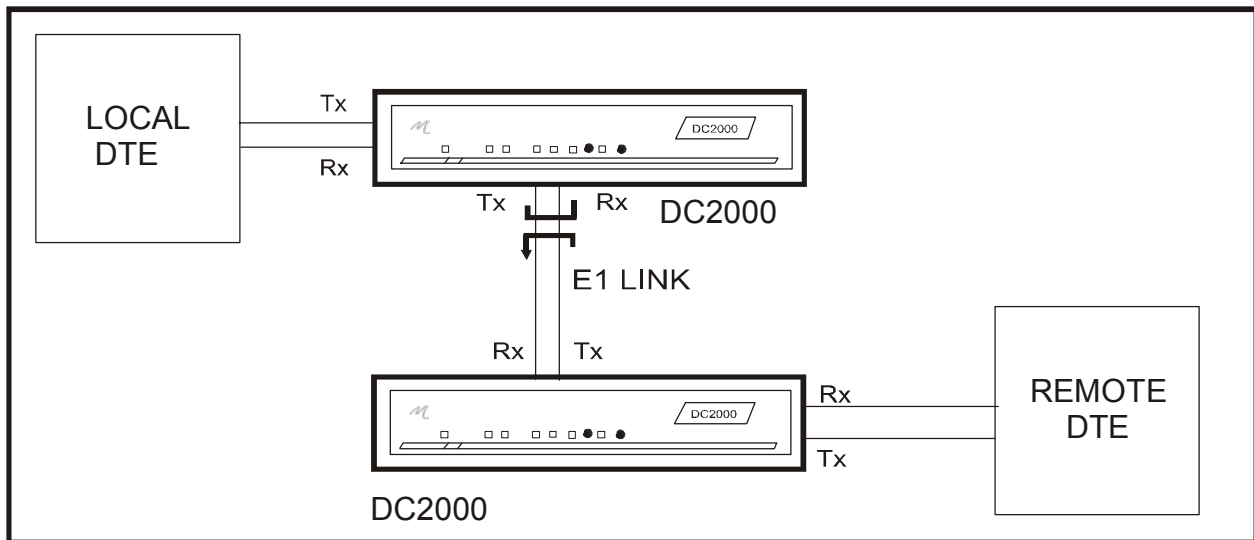

Figure 4.2 Local loop test

When the Local Loop is activated the signal received from the E1 line is passed directly back to the E1 line at the E1 interface.

The signal from the DTE port passes through the DC2000 and is looped adjacent to the E1 port. This therefore validates:

- (a) the local DTE cables if the local DTE recognises its own transmissions.
- (b) the remote DTE cables, the remote DC2000 and the E1 link if the remote DTE recognises its own transmissions.

Pressing the *LOCAL LOOP* press-button again clears the loop.

4.3 Remotely Activated Local Loop

It is also possible to identify that the DC2000 has been looped as a result of a loop-code being received from the remote unit and is signified by the *LOCAL LOOP* LED illuminating. To deactivate the loop, press the *LOCAL LOOP* switch, after which the local loop LED will be extinguished.

4. 4 Troubleshooting

This Section deals with common problems encountered while commissioning the DC2000, and gives advice on how to solve them.

Step 1: Review alarm indicators

In the presence of an alarm condition on the E1 port the following responses are established:

Alarm	Response	Definition
LOS	MAJOR alarm lamp lights <i>DCD NOT ASSERTED</i>	No data is being received at the E1 interface.
AIS	MINOR alarm lamp lights	The DC2000 is receiving 'all 1's' at its E1 interface from a device on the network.

Figure 4.3 E1 Port alarms

Where *LOS* is the Loss Of Signal Alarm and *AIS* is the Alarm Indication Signal.

Step 2: Establish And Verify the E1 Link

Ensure all bit-switches are in the down (ON) position. This is the factory default setting and should be used in the first instance on any installation.

- a) Check for *POWER ON* LED at both ends. If either are off check the mains fuses and the fuses on the rear panels.
- b) If the *MAJOR* alarm LED is on try swapping the BNC connections at one end. It is very easy to get them crossed as one piece of coax looks very much like another.
- c) If the *MAJOR* alarm remains on try looping the BNC connections on one unit. If the *MAJOR* alarm LED goes off then the cabling or the network is faulty. Check for cable continuity and network connections etc.

Step 2: Establish And Verify the DTE Links

- a) If the *MINOR* alarm LED is on check that the routers are switched on.
- b) If the *MINOR* alarm remains on, check that the DTE port/router connections are in place and secure.
- c) If the *MINOR* alarm is still on check the router's configuration. Check to see whether the router's port status is *UP* or *DOWN*.
- d) If the *MINOR* alarm goes out but problems persist, check the DTE cabling configuration. Transmit and Receive data connections may be crossed, as may any of the handshaking/ signalling lines. Also check that line protocol, data scrambling or data/clock inversion are correct at both ends.

Step 3: Bridge/Router Configuration

As the DC2000 is used in a variety of locations and with many different manufacturers' equipment it is impossible for us to cover all eventualities here, so please consult the other manufacturer's operating manual for further information.

5 DC2000 SPECIFICATIONS

5.1 DC2000 Product specification

Parameter	Definition
E1 Network or Line port	G.703 compliant, sensitivity -10dB Line coding HDB3 Interface types: BNC 75 Ohm unbalanced coax 120 Ohm RJ45 per ISO 10173
Jitter Tolerance:	Per G.823
Barrier:	EN 41003 compliant barrier
Framing:	Unframed
Clocking options:	Internal, Receive signal, DTE (circuit 113). See notes below on clocking details
Diagnostics	Local loop, Remote loop, Major/Minor alarm LEDs
DTE Interface	DTE interface provided depends upon model supplied: EIA-530: 25 way female D-type V.35: 34 pin female connector per ISO 2593. X.21: 15-way female D-type per ISO 4903
General	Definition
Power supply	220-240V, 50Hz, 20mA or 110-117V, 60Hz, 40mA
Dimensions	256 x 217 x 47 mm (w x d x h) Table top model
Environmental	Range
Ambient Temperature:	0 degC to +50 degC
Storage Temperature:	-20 degC to +70 degC
Relative Humidity:	0% - 95% non condensing
Barometric Pressure	86 KPa - 106 KPa

Clocking details:

Circuit 113 clock specification: 2.048 MHz \pm 50 ppm. The jitter specification of the DTE clock driving circuit 113 shall be compatible with BS6328 Section 8.1 Clauses 5.2.3.3.1 (a and b) and 5.2.3.3.2 (a, b and c) as defined in BS6328 Section 8.1 Table 8.

Installation and configuration shall be performed in accordance with appropriate jitter control procedures as detailed in BS6328 Section 8.1 Appendix F or equivalent procedures.

5. 2 Glossary

AIS	Alarm Indication Signal
AMI	Alternate Mark Inversion
Clk	Clock
CTS	Clear to Send
DCD	Data Carrier Detect
DSR	Data Set Ready
DSU	Data Service Unit
DTE	Data Terminal Equipment
DTR	Data Terminal Ready
HDB3	High-Density Binary 3
ISO	International Standards Organisation
LAN	Local Area Network
LOS	Loss of Signal Alarm
NI	Network Interface
RT	Receive Timing
RTS	Ready to Send
Rx	Receive
SELV	Safety Extra Low Voltage
ST	Send Timing
Tx	Transmit
TT	Transmit Timing
WAN	Wide Area Network

Disclaimer

Metrodata Ltd makes no representations or warranties with respect to the contents hereof and specifically disclaims any implied warranties or merchantability or fitness for any particular purpose. Further, Metrodata Ltd reserves the right to revise this publication and to make changes from time to time in the content hereof without obligation of Metrodata Ltd to notify any person of such revision or changes.

Trademarks

The Trademarks of other Corporations which may be used in this manual are hereby acknowledged.

Copyright © 2004 by Metrodata Ltd
All Rights Reserved

